

e.h.price

First in Quality, First in Service.

★ Since ★
1961

Serving the
Greater
Toronto Area

e.h.price

STOCK BOOK

JULY 2017



TORONTO

PRODUCTS AVAILABLE FROM:

e.h.price ehpricetoronto.com



Price Industries Ltd
www.price-hvac.com



Greenheck
www.greenheck.com



Honeywell Analytics
www.honeywellanalytics.com



Franklin Control Systems
www.franklin-controls.com



Air Louvers Inc.
www.activarcpg.com/air-louvers



Air Concepts Inc.
www.airconceptsinc.com



Tamco Dampers
www.tamco.ca



Universal Fan & Blower Ltd.
www.universalfan.com



Panasonic ideas for life
www.panasonic.com/building



Plastec Ventilation, Inc
www.plastecvent.net



Fantech
www.fantech.net



Reversomatic
www.reversomatic.com



Broan/NuTone
www.broan-nutone.com



Delhi
www.delhiindustries.com



Rev-Air Innovations
www.dynamicairdiffuser.com



Canarm/Leaderfan
www.canarm.com



Envirofan
www.envirofan.com



Banvil 2000
www.banvil2000.com



Flow Sciences
www.flowsciences.com



Nu-Air Ventilation
www.nu-airventilation.com



Ouellet Electric Heating
www.ouellet.com



Neptronic
www.neptronic.com



Nederman
www.nederman.com



Biddle Climate Solutions
www.biddle.ca



Flanders
www.flanderscorp.com



Enershield
www.enershield.ca



Peppertree Air Solutions
www.peppertreeairsolutions.com



The VMC Group
www.thvmcgroup.com

TABLE OF CONTENTS

PRICE PRODUCTS

RCDE/B12 4
 RCDA/B12 4
 SCD/SCDA Ceiling Diffusers 5
 SPF Drywall Frame 5
 Diffuser Accessories 5
 SPD Diffusers Performance Data 6
 520D - Double Deflection c/w Damper 7
 530 - Fixed Louvers no Damper 8
 80 Grilles 9
 Grille Accessories 9
 Egg Crate Return 9
 ATG1 Door Grilles 10
 SDS4 - Architectural Slot Diffusers 10
 SDS - Linear Slot Diffusers 11
 LTA - Light Troffer Diffusers 12
 TBD3100 - T-Bar Diffusers 13
 VPD-HC / VPD-C Varitherm 14
 SPV8000 Air Volume Rangers c/w CP101 Controller 15
 CP101 - Pneumatic Controller 15
 Heating Coils - 2 Row 15
 ATT-3 - Attenuator 15
 Electronic Controller 16
 FDC5000 - Constant Volume Single Duct Terminal Unit 17
 LGB By-Pass Boxes 18
 LGB - By-Pass Boxes / Control Sequences 19
 LGB By-Pass Box Dimensions 19
 EHC (2502) Electronic Cooling / Heating Changeover 20
 EHC1 (2503) Electronic Cooling / Heating Changeover
 w/1 stage Reheat 20

PANASONIC PRODUCTS

Whisper Ceiling Series - Panasonic Ceiling Mounted Ventilation Fans 23

GREENHECK PRODUCTS

SP B70 Ceiling Exhaust Fans 21
 SP B90-B200 Ceiling Exhaust Fans 21
 SP-A Ceiling Exhaust Fans 22
 SP A900 / A1550 Ceiling Exhaust Fans 23
 CSP A110 / A780 Ceiling Exhaust Fans 24
 CSP A900 / A1750 Cabinet Exhaust Fans 25
 WC Round Wall Cap 25
 SP & CSP Accessories 26
 G - Direct Drive Centrifugal Roof Exhausters 27
 GB - Belt Drive Centrifugal Roof Exhausters 27
 G - Direct Drive Centrifugal Roof Exhausters - Performance Data 28
 GB - Belt Drive Centrifugal Roof Exhausters - Performance Data 29
 Cube - Centrifugal Roof Exhausters Belt Drive, Up Blast 30
 GPI - Prefab Roof Curbs 31

VCE - Vented Curb Extension 31
 CW - Centrifugal Sidewall Exhausters Direct Drive 32
 CW - Centrifugal Sidewall Exhausters Direct Drive
 - Performance Data 33
 CWB - Centrifugal Sidewall Exhausters Belt Drive 34
 SQ - Centrifugal Inline Fans Direct Drive 36
 BSQ - Centrifugal Inline Fans Belt Drive 37
 SE1 - Direct Drive Sidewall Propeller Fans 39
 WD - Motorized or Automatic Backdraft Dampers 40
 MP-100 / MP-300 40
 Quick Delivery / Kitchen Ventilation - Type 1 Hoods 41
 Accessories 41
 Quick Delivery / Kitchen Ventilation 42
 Quick Delivery / Energy Recovery 43
 Quick Delivery / Make-Up Air Systems 44
 IG - Quick Delivery / Make-Up Air Systems 47
 IGX - Quick Delivery / Make-Up Air Systems 47
 Quick Delivery / Ceiling Cabinet & Inline Exhausters 48
 Quick Delivery / Dampers 50

PRICE PRODUCTS

ZE445M - Extruded Aluminum Louver 51
 DE439M - Extruded Aluminum Louver 52
 Fire Dampers - Curtain Type 53
 CFS - Ceiling Fire Stop Flaps 54
 Thermal blankets 54
 Oval Access Doors 54

OTHER COMPANY PRODUCTS

Belimo - Actuators 54
 Honeywell - Actuators 54
 VMC Group - Isolators 55
 Honeywell - E3Point - Toxic & Combustible
 Gas Detector s/a Platform 56
 EnvironAir - APU - Carroll Ecology Unit - Grease /
 Pollution Control Exhausters 60
 Franklin - Building Automation Starters 60
 Franklin - P-Series VFD 62
 Tamco - Dampers 63
 Ortech - Fans 63
 Air Louvers - Adjustable Z-Blade Louvers 64

PRICE RCDE & RCDA DIFFUSERS:



RCDE/B12
Two Position Round Cone Diffusers

Sizes Available in Toronto Branch	CFM			NC 30	
	NC 25	NC 30	NC 35	Radius of Diffusion VT=100	S.P. Horizontal Position
6"	175	200	235	6	.10
8"	240	275	325	7	.09
10"	425	490	500	9	.09
12"	610	705	805	11	.08
14"	680	800	930	12	.10

Performance Notes:

1. Radius of diffusion shown in feet, based on horizontal air pattern and 20°F cooling differential.
2. S.P. shown in inches of water.

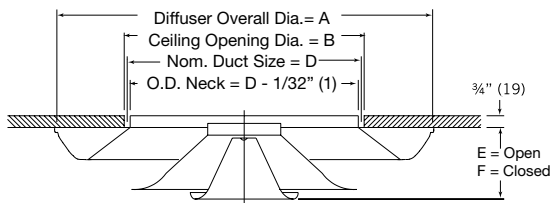

Dimensional Date (Imperial: in. Metric: mm)						
Sizes	A	B	D	E	F	
6"	11 ¹ / ₈ (283)	6 ¹ / ₂ (165)	6 (152)	1 ³ / ₄ (45)	1 ¹ / ₈ (29)	
8"	14 ³ / ₄ (375)	8 ¹ / ₂ (216)	8 (203)	2 ¹ / ₈ (54)	1 ¹ / ₂ (38)	
10"	18 ¹ / ₄ (464)	10 ¹ / ₂ (267)	10 (254)	2 ⁷ / ₈ (73)	2 ¹ / ₈ (54)	
12"	22 (559)	12 ¹ / ₂ (318)	12 (305)	3 ¹ / ₈ (79)	2 ³ / ₈ (60)	
14"	26 (660)	14 ¹ / ₂ (368)	14 (356)	3 ³ / ₄ (86)	2 ⁵ / ₈ (67)	



RCDA/B12
Adjustable Round Cone Diffusers

Sizes Available in Toronto Branch	CFM			NC 30	
	NC 25	NC 30	NC 35	Radius of Diffusion VT=100	S.P. Horizontal Position
6"	165	195	228	5	.07
8"	275	325	385	6	.06
10"	415	490	580	8	.06
12"	590	685	810	9	.06
14"	770	880	1060	10	.05
16"	980	1155	1365	11	.05

Performance Notes:

1. Radius of diffusion shown in feet, based on horizontal air pattern and 20°F cooling differential.
2. S.P. shown in inches of water.

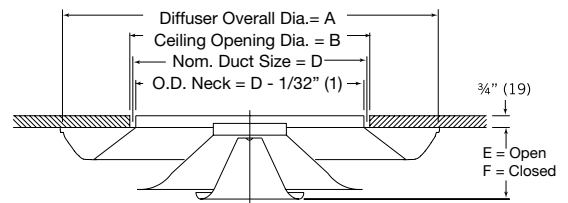

Dimensional Date (Imperial: in. Metric: mm)						
Sizes	A	B	C	D	E	F
6"	13 ¹ / ₂ (343)	12 (305)	1 ⁵ / ₈ (41)	6 (44)	1 ³ / ₄ (44)	1 ⁵ / ₁₆ (24)
8"	18 (457)	16 (406)	2 ¹ / ₈ (54)	8 (56)	2 ³ / ₁₆ (56)	1 ³ / ₁₆ (30)
10"	22 ¹ / ₂ (572)	20 (508)	2 ⁵ / ₈ (67)	10 (68)	2 ¹¹ / ₁₆ (68)	1 ⁷ / ₁₆ (37)
12"	27 (686)	24 (610)	3 ¹ / ₄ (83)	12 (79)	3 ¹ / ₈ (79)	1 ⁵ / ₈ (41)
14"	31 ¹ / ₂ (800)	28 (711)	3 ³ / ₄ (95)	14 (100)	3 ¹⁵ / ₁₆ (100)	1 ¹⁵ / ₁₆ (49)
16"	36 (914)	32 (813)	4 ¹ / ₄ (108)	16 (108)	4 ¹ / ₄ (108)	2 ¹ / ₄ (57)

PRICE SCD CEILING DIFFUSERS:



SCD/31/24x24/B12
Square Cone
Diffusers



SCD/31/20x20/B12
Square Cone
Diffusers

Sizes Available in Toronto Branch	CFM			NC 30		
	20x20	NC 25	NC 30	NC 35	VT=50	S.P.
4"		122	145	173	6	.06
5"		163	190	220	8	.07
6"		209	243	289	8	.08
8"		305	361	419	11	.13
6"	•	189	230	274	6	.05
8"	•	314	377	454	8	.05
10"	•	464	545	654	8	.07

Still one of the most efficient diffusers for any application. Ideal for VAV applications. Specially designed to eliminate the causes of ceiling smudging and streaking.

Performance Notes:

1. Throw data based on supply air and room air being at isothermal conditions.
2. S.P. shown in inches of water.

PRICE SDCA DIFFUSERS:



SCDA/3/24x24/B12
Adjustable Square Cone Diffusers -
24 x 24 Full Face Model T-Bar Mount

Duct	CFM			NC 30	
	NC 25	NC 30	NC 35	Radius of Diffusion VT=100	S.P.
6	1856	213	280	4	.05
8	305	349	407	7	.07
10	450	518	600	8	.09
12	609	707	811	9	.09

Performance Notes:

1. Throw data based on supply air and room air being at isothermal conditions.
2. S.P. shown in inches of water.
3. The above performance data is for horizontal projection. For vertical performance data, see the Price Air Distribution Products catalogue.

PRICE SPF DRYWALL FRAME FOR ACCESS INTO CEILING:

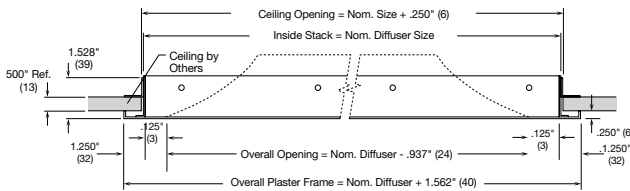

24 x 24 Ceiling Diffusers and Registers

12 x 12	24 x 24	20 x 20

PRICE DIFFUSER ACCESSORIES:

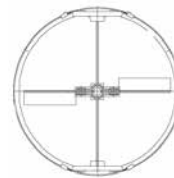

VRC8
Volume Control Damper

6"	10"
8"	12"

PRICE DIFFUSER ACCESSORIES:



EG
Equalizing Grid

6"	10"
8"	12"

PRICE SPD DIFFUSERS:



SPD/31/24x24/B12
Square Plaque Diffusers -
24 x 24 Full Face Model

Price SPD Series square plaque diffuser satisfies both architectural appeal and engineering performance criteria. Simple, clean and unobtrusive face design is intended to blend with most ceiling systems.

- Heavy gauge steel construction.
- Face panel has smooth edges and rounded off corners to blend with back cone.
- Back cone is one piece die-formed with smooth, aerodynamically designed surfaces and no corner joints.
- Helps prevent ceiling smudging.
- The back cone shape combines with the face panel to deliver a tight, 360° radial horizontal air pattern.
- Face panel is easily installed and removed without special tools.
- Maintains true horizontal air pattern even at low air volumes making it excellent for VAV applications.

Performance Data : 24 x 24 (600 x 600) Face Size

Listed Sizes	Neck Velocity, fpm	400	500	600	700	800	900	1000	1200	1400	1600
	Velocity Pressure, in w.g.	.010	.016	.022	.031	.040	.050	.062	.090	.122	.160
6	Total Pressure, in w.g.	.010	.016	.023	.032	.041	.053	.065	.093	.127	.166
	Flow Rate, cfm	78	98	118	137	157	176	196	235	274	314
	NC	-	-	-	-	-	19	22	29	34	38
	Throw 150, 100, 50	1-2-4	1-2-4	2-3-5	2-3-6	2-4-6	3-4-7	3-4-7	4-5-8	4-6-9	5-7-9
8	Total Pressure, in w.g.	.018	.029	.042	.057	.074	.093	.115	.166	.226	.295
	Flow Rate, cfm	140	175	209	244	279	314	349	419	489	558
	NC	-	-	-	-	19	23	27	33	38	43
	Throw 150, 100, 50	2-2-5	2-3-6	2-4-7	3-4-8	3-5-9	4-6-9	4-6-10	5-7-11	6-8-12	7-9-12
10	Total Pressure, in w.g.	.029	.045	.065	.088	.115	.146	.180	.259	.353	.461
	Flow Rate, cfm	218	273	327	382	436	491	545	654	763	872
	NC	-	-	-	18	22	26	30	36	41	46
	Throw 150, 100, 50	2-3-6	3-4-8	3-5-9	4-6-10	4-6-11	5-7-12	5-8-12	6-9-13	8-10-14	9-11-15
12	Total Pressure, in w.g.	.041	.065	.093	.127	.166	.210	.259	.373	.508	.664
	Flow Rate, cfm	314	393	471	550	628	707	785	942	1099	1256
	NC	-	-	-	21	25	29	33	39	44	49
	Throw 150, 100, 50	3-4-8	3-5-10	4-1-11	5-1-12	5-8-13	5-8-13	7-10-15	8-11-16	9-12-17	11-13-9

Performance Data : 12 x 12 (300 x 300) Face Size

Listed Sizes	Neck Velocity, fpm	400	500	600	700	800	900	1000	1200	1400	1600
	Velocity Pressure, in w.g.	.010	.016	.022	.031	.040	.050	.062	.090	.122	.160
6	Total Pressure, in w.g.	.038	.059	.085	.116	.152	.192	.237	.341	.464	.606
	Flow Rate, cfm	78	98	118	137	157	176	196	235	274	314
	NC	-	-	-	-	-	18	23	31	43	49
	Throw 150, 100, 50	2-3-6	2-4-7	3-4-8	3-5-9	4-6-10	4-7-10	5-7-11	6-8-12	7-9-13	8-10-14
8	Total Pressure, in w.g.	.068	.106	.153	.208	.271	.343	.424	.610	.831	1.085
	Flow Rate, cfm	140	175	209	244	279	314	349	419	489	558
	NC	-	-	-	-	17	22	27	27	43	49
	Throw 150,100,50	3-4-8	3-5-10	4-6-11	5-7-12	6-8-13	6-9-14	7-10-15	7-10-15	10-12-17	11-13-18

Performance Data : 20 x 20 (500 x 500) Face Size

Listed Sizes	Neck Velocity, fpm	400	500	600	700	800	900	1000	1200	1400	1600
	Velocity Pressure, in w.g.	.010	.016	.022	.031	.040	.050	.062	.090	.122	.160
6	Total Pressure, in w.g.	.014	.022	.031	.043	.056	.071	.087	.126	.171	.223
	Flow Rate, cfm	78	98	118	137	157	176	196	235	274	314
	NC	-	-	-	-	-	18	21	27	32	36
	Throw 150, 100, 50	0-1-3	1-2-4	1-2-4	1-3-5	2-3-6	2-3-6	3-4-7	3-4-7	3-5-7	4-6-8
8	Total Pressure, in w.g.	.022	.035	.050	.069	.090	.114	.140	.202	.275	.359
	Flow Rate, cfm	140	175	209	244	279	314	314	419	489	558
	NC	-	-	-	16	20	24	24	33	38	42
	Throw 150, 100, 50	1-2-5	2-3-6	2-4-6	3-4-7	3-5-7	4-5-8	4-5-8	5-6-9	6-7-10	6-7-11
10	Total Pressure, in w.g.	.032	.051	.073	.099	.130	.164	.203	.292	.397	.519
	Flow Rate, cfm	218	273	327	382	436	491	545	654	763	872
	NC	-	-	-	20	24	28	31	37	42	46
	Throw 150, 100, 50	2-3-6	3-4-7	3-5-8	4-6-9	4-6-9	5-7-10	5-7-10	6-8-11	7-9-12	8-9-13

PRICE 520D - DOUBLE DEFLECTION C/W DAMPER:

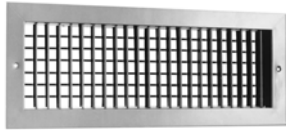

520D/F/S/A/B12
Double Deflection Louvered
Supply Grilles c/w Damper

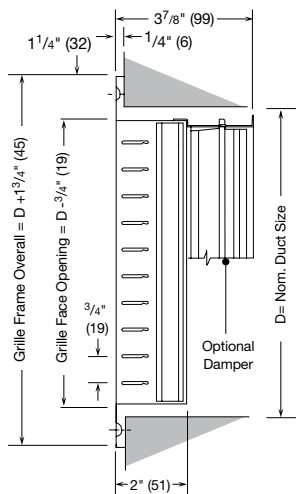

- F - Border
- S - Blades in front to short dimension
- A - Screw hole fastenings

Size	CFM			NC 30	
	NC 25	NC 30	NC 35	Throw VT=100	S.P.
6 x 4	108	128	180	16	.10
6 x 6	170	200	235	18	.10
8 x 4	170	200	235	18	.10
8 x 6	239	277	324	22	.093
8 x 8	333	390	470	26	.084
10 x 4	205	243	283	20	.098
10 x 6	293	352	410	24	.069
10 x 8	383	447	532	26	.064
10 x 10	480	566	672	31	.075
12 x 4	239	277	324	22	.093
12 x 6	333	390	470	26	.084
12 x 8	480	566	672	31	.075
12 x 10	534	643	760	33	.074
12 x 12	675	797	936	37	.054
14 x 4	266	312	372	23	.090
14 x 6	383	447	532	26	.084
14 x 8	534	643	760	33	.074
16 x 6	430	505	590	30	.084
16 x 8	629	741	890	34	.071
16 x 10	675	797	936	37	.067
16 x 16	1120	1326	1554	47	.058
18 x 4	333	390	470	26	.084
18 x 6	480	566	672	31	.075
18 x 8	675	797	936	37	.067
18 x 12	973	1147	1340	44	.063
20 x 6	534	643	760	33	.074
24 x 4	430	505	590	30	.050
24 x 6	659	778	932	35	.071
24 x 8	855	1012	1180	41	.063
24 x 10	1045	1237	1450	46	.054
24 x 12	1224	1440	1697	49	.048
24 x 18	1782	2085	2500	59	.044
24 x 24	2242	2620	3096	66	
30 x 6	776	927	1105	40	.064
30 x 8	1070	1261	1473	46	.063
30 x 10	1278	1504	1772	50	.054
30 x 12	1511	1772	2089	55	.077
36 x 18	2656	3108	3676	72	.044

Performance Notes:

1. Throw data based on supply air and room air being at isothermal conditions.
2. S.P. shown in inches of water.

PRICE 530 - FIXED LOUVERS NO DAMPER:



530/F/L/A/B12
Single Deflection
Fixed Blade Louvered
Return Grilles

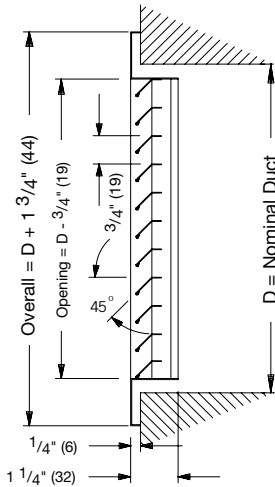

530 / F / L / A / B12 (White)
3/4" (19) Blade Spacing
Fixed Louvers, No Damper

Size	CFM			NC 30
	NC 25	NC 30	NC 35	S.P.
6 x 4	66	80	98	0.15
6 x 6	110	130	162	0.15
8 x 4	110	130	162	0.15
8 x 6	156	185	215	0.14
8 x 8	225	265	320	0.13
10 x 4	132	160	195	0.13
10 x 6	200	238	275	0.136
10 x 8	255	310	368	0.13
10 x 10	315	390	480	0.132
12 x 4	156	185	215	0.14
12 x 6	225	265	320	0.13
12 x 8	315	390	480	0.12
12 x 10	370	450	540	0.125
12 x 12	470	570	682	0.11
14 x 4	170	210	255	0.136
14 x 6	255	310	368	0.13
14 x 8	370	450	540	0.12
14 x 10	470	570	615	0.125
14 x 14	590	725	840	0.11
16 x 6	290	342	416	0.125
16 x 8	470	570	615	0.11
16 x 12	590	725	840	0.115
16 x 16	800	960	1120	0.10
18 x 6	315	390	480	0.12
18 x 8	470	570	682	0.11
18 x 12	670	804	950	0.10
18 x 18	980	1210	1458	0.115
20 x 10	590	725	840	0.115
24 x 6	470	570	682	0.11
24 x 8	590	725	840	0.115
24 x 12	860	1040	1260	0.115
24 x 16	1140	1380	1670	0.09
24 x 18	1300	1550	1890	0.09
24 x 24	1023	1232	1500	0.045
30 x 8	670	804	950	0.10
30 x 18	1624	1950	2345	0.08
36 x 18	1930	2290	2788	0.08
36 x 24	2450	2910	3450	0.075
42 x 14	1930	2290	2788	0.081
42 x 24	2650	3300	3900	0.151

Performance Notes:
1. S.P. shown in inches of water.

PRICE 80 GRILLES: **PRICE GRILLE ACCESSORIES:**



80/F/SW/A/B12
Egg Crate Return Grilles Surface Mount, F Border

CFM				NC 30
Size	NC 25	NC 30	NC 35	S.P. in.
6 x 6	165	190	216	0.182
8 x 4	165	190	216	0.182
8 x 6	200	260	290	0.172
8 x 8	280	360	410	0.162
10 x 4	200	235	257	0.182
10 x 6	280	330	365	0.162
10 x 10	480	530	640	0.150
12 x 4	200	260	290	0.172
12 x 6	20	360	410	0.162
12 x 8	480	530	640	0.150
12 x 10	552	600	710	0.143
12 x 12	690	840	900	0.140
14 x 10	630	750	830	0.143
14 x 14	840	980	1110	0.140
16 x 6	430	490	570	0.195
16 x 8	630	750	830	0.143
16 x 16	1220	1380	1500	0.130
18 x 8	690	840	900	0.140
20 x 12	1220	1340	1500	0.132
20 x 20	2020	2290	2600	0.110
24 x 6	690	840	900	0.145
24 x 12	1310	1490	1700	0.124
24 x 18	1900	2180	2450	0.104
24 x 24	2350	2790	3200	0.104
42 x 12	2488	2850	3350	0.115
42 x 14	2350	2790	3200	0.104

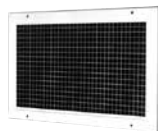

80D/F/SW/A/B12
Egg Crate Return Register Surface Mount,
F Border w/ Damper

CFM				NC 30
Size	NC 25	NC 30	NC 35	S.P. in.
10 x 10	480	570	660	0.0725
12 x 10	710	805	900	0.075



VCS3
Grille Mounted Opposed Blade Damper

6 x 6	8 x 6	8 x 8
10 x 6	10 x 10	12 x 6
12 x 8	12 x 12	24 x 12
24 x 24		

PRICE EGG CRATE RETURN:

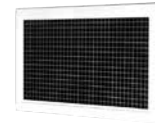

80/ /LI/B12
1/2" Egg Crate Return, T-Bar Lay-In Models, No Damper

CFM				NC 30
Size	NC 25	NC 30	NC 35	S.P. in.
6 x 6	165	190	216	0.182
8 x 8	280	360	410	0.162
12 x 12	690	840	900	0.14
20 x 10	940	1180	1340	0.132
20 x 12	1460	1545	1760	0.128
20 x 20	1900	2180	2450	0.104
24 x 6	690	840	900	0.145
24 x 12	1310	1490	1700	0.124
24 x 24	2350	2790	3200	0.104

Performance Notes:

- Returns with NF borders have duct connections 3/4 in. smaller than those for F borders.

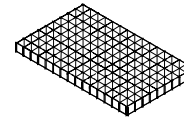

80 Core/B12
Egg Crate Returns (Core Only), T-Bar Lay-In Models, Aluminum Grid 0° Deflection, 1/2" x 1/2" x 1/2" (13)

CFM				NC 30
Size	NC 25	NC 30	NC 35	S.P. in.
20 x 10	1040	1180	1365	0.60
20 x 20	2224	2600	2925	0.050
24 x 12	1550	1740	1990	0.115
24 x 24	2350	2790	3200	0.104
48 x 24	4700	5580	6400	.06
60 x 30	7450	7450	8650	.06

PRICE ATG1 DOOR GRILLES: **PRICE** SDS4 - ARCHITECTURAL SLOT DIFFUSERS:

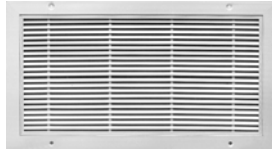

ATG1/BF/B15

Aluminum Transfer/Door Grilles w/ Border on Both Sides

Size	CFM	
	$\Delta P = .02"$	$\Delta P = .06"$
12 x 6	59	78
12 x 8	90	120
12 x 12	135	180
14 x 8	100	140
16 x 8	122	162
16 x 10	135	180
16 x 14	201	268
18 x 12	201	268
18 x 18	312	416
20 x 10	177	236
24 x 12	270	360
24 x 16	368	490
24 x 18	417	556
24 x 24	542	722

Performance Notes:

1. S.P. shown in inches of water.

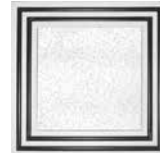

SDS475/14/24x24/B12

Architectural Slot Diffuser - 4 Way 2 Slot Linear Diffuser

CFM			NC 30	
NC 25	NC 30	NC 35	Radius of Diffusion VT=50	S.P. Horizontal Position
175	200	235	6	.10
240	275	325	7	.09
425	490	580	9	.09
610	705	805	11	.08
680	800	930	12	.10

Note: Tile Insert Not Included

Performance Notes:

1. Throw data based on supply air and room air being at isothermal conditions.
2. S.P. shown in inches of water.
3. Plenums available with inlet sizes 6", 8", 10" & 12"

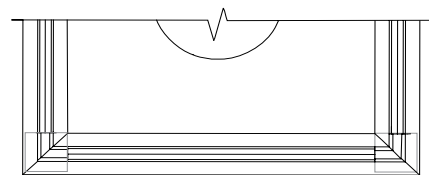

PRICE SDS - LINEAR SLOT DIFFUSERS

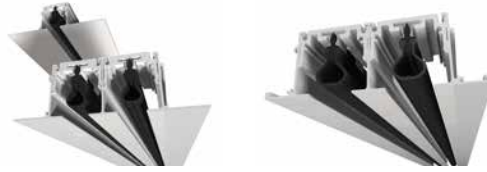

SDS, SIZES 0.75" (75) AND 1" (100)

1 and 2 slots available in various lengths (24", 48", 60", 72") and end conditions (XX, XY, YY).
Check availability with E.H. Price contractor counter or sales team.

SDS75

Slots	Total	H	0.004	0.015	0.032	0.058	0.091	0.125	0.175	0.23
	Pressure	V	0.003	0.011	0.024	0.044	0.067	0.095	0.125	0.17
1	cfm / ft		6	12	18	24	30	36	42	48
	Throw	H	1-1-2003	1-3-2009	3-6-11	5-9-13	8-10-15	9-11-16	10-12-17	11-13-19
		V	2	6	10	12	14	15	16	17
	NC		—	—	—	18	24	30	35	39
2	cfm / ft		12	24	36	48	60	72	84	96
	Throw	H	1-1-2005	2-5-13	5-10-16	9-13-19	11-15-21	13-16-23	14-17-25	15-19-27
		V	4	9	14	17	19	21	23	24
	NC		—	—	—	23	29	35	40	44

SDS100

Slots	Total	H	0.004	0.016	0.037	0.064	0.098	0.14	0.195	0.25
	Pressure	V	0.002	0.009	0.022	0.038	0.058	0.084	0.115	0.15
1	cfm / ft		8	16	24	32	40	48	56	64
	Throw	H	1-1-2003	2-3-11	3-8-13	6-11-15	9-12-17	11-13-19	12-14-20	12-15-22
		V	2	8	12	14	15	17	18	19
	NC		—	—	—	22	29	34	39	43
2	cfm / ft		16	32	48	64	80	96	112	128
	Throw	H	1-2-06	3-6-15	6-12-19	11-15-22	14-17-24	15-19-27	16-25-28	18-22-31
		V	5	11	16	19	22	24	26	28
	NC		—	—	18	27	34	39	44	48

Performance Notes:

- All pressures are in in. w.g.
- Horizontal throw based on velocity 150 fpm – 100 fpm – 50 fpm
- Vertical throw based on 50 fpm
- Throw data based on isothermal conditions; sound based on ASHRAE 70-2006 method of testing.
- Data based on pressurized plenum. For individual plenum data, see Price catalogue for SDB-SDA model.

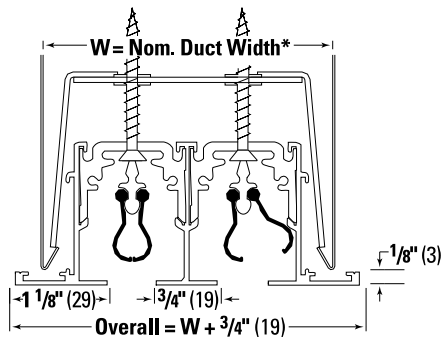

Surface Mount – Concealed
Type 2 Flanged frame

# Slots	Frame 2 "W" Dimension	
	SDS75 – 0.75"	SDS100 – 1"
1	2.25"	2.5"
2	3.75"	4.25"

Note:

Other types of frames, plenums or end conditions available to order.

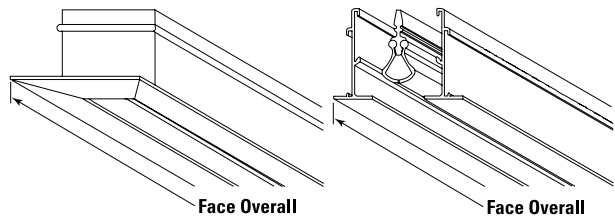

Type X - Mitered End Flange

Type Y - Open End

PRICE LTA - LIGHT TROFFER DIFFUSERS:



LTA/LP/KD

Light Troffer Diffuser - Saddle Type Supply Diffuser

Cross-Over is adjustable to Suit Various Light Fixture Widths

Size	CFM			NC 30		
	W	NC 25	NC 30	NC 35	Throw VT=50	S.P.
LTA 14 / LP	8" - 13"	128	150	180	13	.15
LTA 24 / LP	13" - 24"	128	150	180	13	.15

Performance Notes:

1. Throw shown in feet, based on horizontal projection and 20°F cooling differential.
2. T.P. is shown in inches of water.

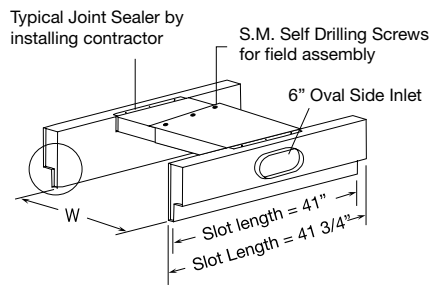
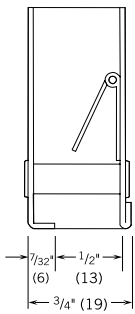

Nose Detail

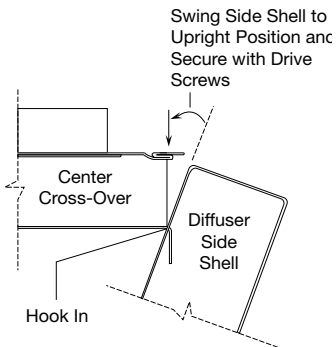

Field Assembly of Cross-Over to Shell

Saddle Type Supply Diffusers

- Double Side Straddle Type Supply
- Supplied Knocked Down for Field Assembly by Installer
- c/w 6" Oval Side Inlet (3" x 79/16")
- Cross-Over is Field Adjustable
- Width 8" - 14" / 14" - 24"

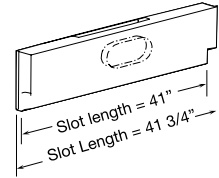
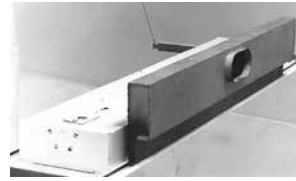

LTA 10-4

Light Troffer Diffuser - Single Sided Supply Diffuser

Size	CFM			Throw VT=50	S.P.
	NC 25	NC 30	NC 35		
10-4	85	97	112	9	.185

Performance Notes:

1. Throw data based on supply air and room air being at isothermal conditions.
2. T.P. is shown in inches of water.

PRICE TBD3100 - T-BAR DIFFUSERS:

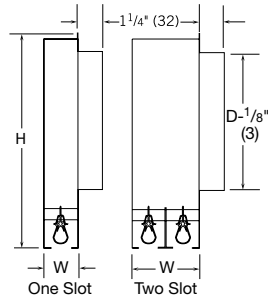

TBD3100 - 2 Slot T-Bar Diffusers

Model TBD3100 1 Slot										
	CFM	40	50	60	70	80	90	100	110	120
Module = 24" 6" Diameter Inlet	Total Pressure	0.06	0.09	0.12	0.17	0.22	0.28	0.34	0.42	0.50
	Static	0.05	0.07	0.09	0.13	0.17	0.21	.026	0.32	0.38
	Throw	3-6-19	4-9-21	6-13-23	8-17-23	10-19-27	12-20-28	16-21-30	18-22-31	19-23-32
	NC (Noise Criteria)	15	22	28	28	36	36	43	46	49
Module = 36" 6" Diameter Inlet	CFM	50	60	70	80	90	100	110	120	130
	Total Pressure	0.03	0.07	0.10	0.12	0.16	0.19	0.24	0.28	0.33
	Static	0.01	0.04	0.06	0.07	0.09	0.11	0.14	0.16	0.19
	Throw	3-6-18	4-18-20	6-12-21	7-16-23	9-17-24	11-18-26	13-19-27	16-20-28	17-21-29
Module = 48" 6" Diameter Inlet	CFM	70	80	90	100	120	140	160	180	200
	Total Pressure	0.05	0.06	0.08	0.09	0.14	0.19	0.24	0.31	0.38
	Static	0.03	0.04	0.05	0.06	0.09	0.12	0.15	0.20	0.25
	Throw	3-6-13	4-8-15	5-9-17	5-10-19	8-12-22	9-14-23	10-15-25	12-17-27	13-19-28
Module = 60" 6" Diameter Inlet	CFM	210	240	270	300	330	360	390	420	450
	Total Pressure	0.07	0.09	0.11	0.13	0.16	0.19	0.23	0.26	0.30
	Static	0.05	0.06	0.07	0.08	0.10	0.12	0.15	0.17	0.20
	Throw	6-01-20	8-11-22	9-12-25	9-14-28	10-15-29	11-17-30	12-1-32	13-20-33	14-21-34
NC (Noise Criteria)	21	25	27	34	34	37	40	42	44	

Model TBD3100 2 Slot										
	CFM	150	175	200	225	250	275	300	325	350
Module = 24" 6" Diameter Inlet	Total Pressure	0.05	0.07	0.09	0.12	0.15	0.18	0.21	0.25	0.29
	Static	0.03	0.04	0.06	0.08	0.10	0.11	0.13	0.16	0.18
	Throw	7-10-20	8-12-23	9-13-27	10-15-30	11-16-31	12-18-33	13-20-34	14-21-36	15-23-37
	NC (Noise Criteria)	17	22	26	30	33	36	38	41	43
Module = 36" 6" Diameter Inlet	CFM	210	240	270	300	330	360	390	420	450
	Total Pressure	0.07	0.09	0.11	0.13	0.16	0.19	0.23	0.26	0.30
	Static	0.05	0.06	0.07	0.08	0.10	0.12	0.15	0.17	0.20
	Throw	6-10-20	8-11-22	9-12-25	9-14-28	10-15-29	11-17-30	12-18-32	13-20-33	14-21-34
NC (Noise Criteria)	21	25	27	31	34	37	40	42	44	

Dimensions (inches)				
Model	Module	H	D	W
TBD3100 - 1 Slot	48	10	6	1 3/4
	60	12	8	1 3/4
TBD3100 - 2 Slot	48	12	8	3 1/2
	60	12	8	3 1/2

PRICE VPD-HC / VPD-C - VARITHERM:

AVAILABLE TO ORDER



VPD-HC/VPD-C
Varitherm Thermally
Powered VAV Diffuser

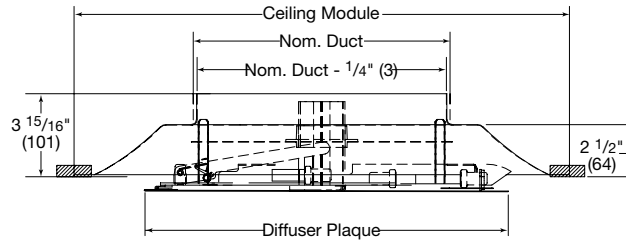

Inlet Size	Neck Velocity Velocity Pressure	400 0.010	500 0.016	400 0.022	400 0.031	400 0.040	400 0.050	400 0.062
6"	Static Pressure	0.046	0.071	0.103	0.139	0.182	0.231	0.284
	Total Pressure	0.056	0.087	0.125	0.169	0.222	0.282	0.346
	CFM	79	98	118	137	157	177	196
	NC	—	—	18	22	26	30	33
	Throw, ft	0-1-3	1-2-3	1-2-3	2-2-4	2-2-4	2-3-4	2-3-4
8"	Static Pressure	0.035	0.054	0.077	0.105	0.137	0.174	0.215
	Total Pressure	0.045	0.070	0.099	0.136	0.177	0.224	0.277
	CFM	140	175	209	244	279	314	349
	NC	—	17	22	26	30	34	37
	Throw, ft	2-3-7	3-4-7	3-5-8	4-6-9	5-7-9	5-7-10	6-7-11
10"	Static Pressure	0.031	0.049	0.070	0.096	0.124	0.158	0.194
	Total Pressure	0.041	0.064	0.092	0.126	0.164	0.208	0.257
	CFM	218	273	327	382	436	491	545
	NC	—	19	24	29	33	36	39
	Throw, ft	4-5-9	4-7-11	5-8-12	6-9-12	7-9-13	8-10-14	9-11-15
12"	Static Pressure	0.046	0.071	0.103	0.140	0.183	0.231	0.285
	Total Pressure	0.056	0.087	0.125	0.171	0.222	0.282	0.348
	CFM	314	393	471	550	628	707	785
	NC	19	25	30	35	38	42	45
	Throw, ft	5-8-11	6-9-13	8-10-14	9-11-15	9-11-16	10-12-17	10-13-18
14"	Static Pressure	0.057	0.088	0.127	0.173	0.226	0.286	0.353
	Total Pressure	0.067	0.104	0.149	0.203	0.266	0.336	0.415
	CFM	428	535	641	748	855	962	1069
	NC	23	29	34	38	41	44	47
	Throw, ft	7-9-13	8-10-15	9-11-16	10-12-17	11-13-19	11-14-20	12-15-21

- Steel back pan, faceplate and linkage for strength and durability
- Thermal elements for consistent, repeatable performance
- Hinged faceplate, with magnetic closure, that also allows for quick access to adjustment features.
- Specially engineered damper stack for reduced linkage binding over the entire operating range.

Performance Notes:

1. Performance data is presented for the Prodigy diffuser with the inner cone in the full open (maximum flow) position.
2. Tested in accordance with ASHRAE Standard 70-1991 "Method of Testing for Rating the Performance of Air Outlets and Inlets"
3. Air flow is in cubic feet per minute, CFM.
4. All pressures are in inches of water.
5. Throw values are given in feet to terminal velocities of 150-100-50 fpm.
6. Throw data is based on supply air and room air at isothermal conditions.
7. Tested in accordance with ASHRAE Standard 70-1991 "Method of Testing for Rating the Performance of Air Outlets and Inlets"
8. Air flow is in cubic feet per minute, CFM.
9. Throw values are given in feet to terminal velocities of 150-100-50 fpm.
10. Throw data is based on supply air and room air at isothermal conditions.
11. The NC values, sound pressure level, are based on a room absorption of 10 dB re 10-12 watts and one diffuser.
12. Blanks "—" indicate an NC level below 15.
13. The NC values, sound pressure level, are based on a room absorption of 10 dB re 10-12 watts and one diffuser.
14. Blanks "—" indicate an NC level below 15.

Dimensional Data (in./mm)		
Ceiling Module		Nominal Duct
Imperial	Metric	
24 x 24 (610 x 610)	600 x 600	6,8,10,12,14 (152,203,254,305,356)

PRICE SPV8000 AIR VOLUME RANGERS C/W CP101 CONTROLLER:



SPV 8000
Single Duct Terminal Unit
c/w pneumatic Controls

SPV8000 / SDV5000 Single Duct NO / DA

- Variable Volume Assemblies
- Pneumatic Control (c / w Pneumatic Actuator)
- Units available "Bare Box" (No Controller) (SDV)

Recommended Air Volume Ranges for SPV8000 c/w CP101 Controller					Recommended Air Volume Ranges for SPV5000 c/w Electronic or Digital Controls					Stock Calibration CFM
Unit Size	L/s Min.*	L/s Max.	cfm Min.*	cfm Max.	Unit Size	L/s Min.*	L/s Max.	cfm Min.*	cfm Max.	
4	24	106	50	225	4	24	106	50	225	0 / 200
5	30	165	63	350	5	30	165	63	350	0 / 250
6	31	212	66	450	6	31	212	66	450	0 / 300
7	47	307	99	650	7	47	307	99	650	0 / 450
8	62	378	132	800	8	62	378	132	800	0 / 600
9	79	496	167	1050	9	79	496	167	1050	0 / 850
10	104	637	221	1350	10	104	637	221	1350	0 / 950
12	143	991	304	2100	12	143	991	304	2100	0 / 1700
14	207	1416	439	3000	14	207	1416	439	3000	0 / 2200
16	268	1888	568	4000	16	268	1888	568	4000	0 / 4000
24 x 16	560	3775	1187	8000	24 x 16	500	3775	1187	8000	N/A

*Note: For 4 & 5 box sizes use a size 6 with the appropriate reducer.

PRICE CP101 - PNEUMATIC CONTROLLER:



CP-101 & CSC-3011
Replacement Controller for the SPV Terminal Unit

Also available CP100 Controllers for replacement parts

- Provides accurate control over a duct velocity range of 0 - 3000 fpm.
- Operates at low system pressures. As effective at 0.02" w.g. as at 6" w.g.
- Completely pressure independent.
- Adjustable minimum and maximum air volume settings easily field adjusted if required.
- Reset span remains constant regardless of maximum and minimum air volume adjustments.
- Provides constant 5 psi reset span as per standard factory calibration.
- Has adjustable start point for reset span to accommodate auxiliaries such as reheat coils.
- Includes option to expand reset span to 10 psi to accommodate most thermostats.
- Adjustable to accommodate either direct acting or reverse acting thermostats. Also settings for either normally open or normally closed damper operation without added control components.
- Standard mounting face down. All adjustments are directly accessible through a ceiling opening.

PRICE HEATING COILS - 2 ROW

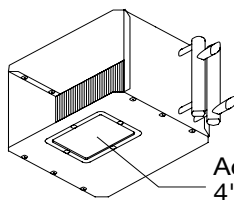

Access Doors
4" x 6 3/4 (102 x 171)
Top & Bottom
Coil Section c/w CAD (Coil Access Door)

Dimensional Data - inches / mm		
Unit Size	B (Width)	C (Height)
4, 5, 6	12 (305)	8 (203)
7, 8	12 (305)	10 (254)
9, 10	14 (356)	12 1/2 (318)
12	16 (406)	15 (381)

PRICE ATT-3 - ATTENUATOR



ATT-3
3 Foot Attenuator Section for SDV & SPV Terminal Units

Unit Size	B (Width)	C (Height)
4, 5, 6	12	8
7, 8	12	10
9, 10	14	12 1/2
12	16	15
14	20	17 1/2
16	24	18

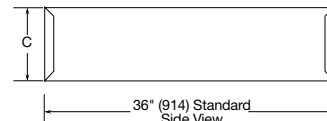
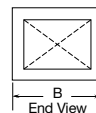

PRICE ELECTRONIC CONTROLLER



DDC - Electronic Control

- Custom Controls Mounted in Toronto.
- Please contact your sales representative for information.

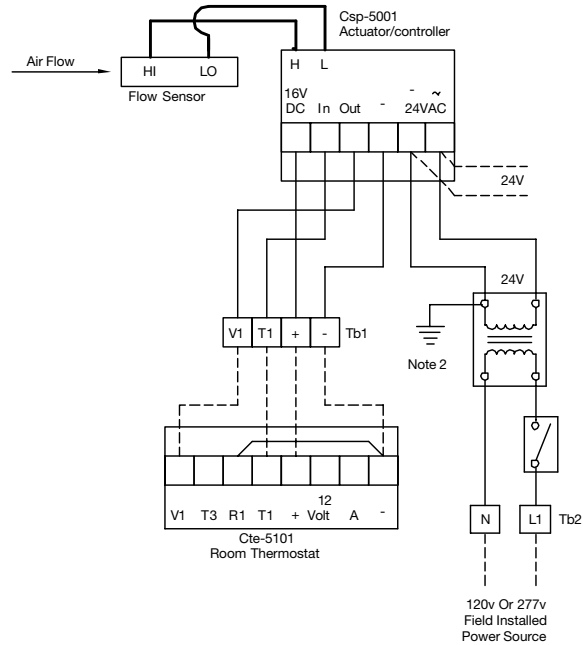

SEV - Single Duct Electronic Controls

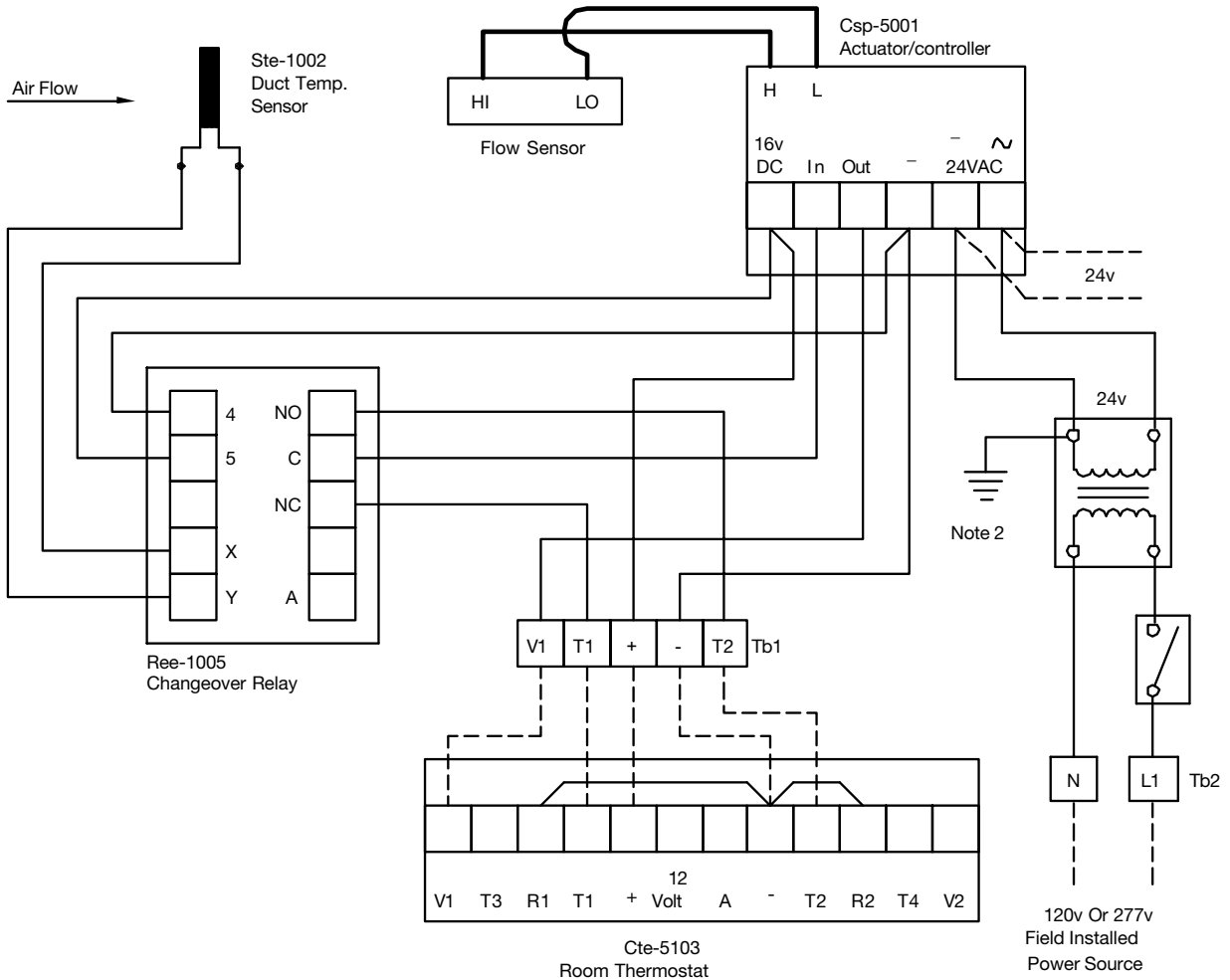

PRICE FDC5000 - CONSTANT VOLUME SINGLE DUCT TERMINAL UNIT:

AVAILABLE TO ORDER



FDC5000
Single Duct Terminal Unit
Constant Volume

Dimensional Data - inches / mm.										
Unit Size	Max. Fan cfm	Primary Air Inlet A	Return Air Inlet D	Return Air Inlet E	Outlet Duct Size B	Outlet Duct Size C	Outlet Duct Size W	Outlet Duct Size H	Outlet Duct Size L	Outlet Duct Size F
20	700 (300)	6, 8 (150, 203)	9 (229)	12 (305)	12 (305)	10 (254)	24 (610)	14 (356)	28 (711)	4 (101)
30	1200 (566)	8, 10 (203, 254)	13 (330)	15 1/2 (394)	14 (356)	12 1/2 (378)	30 (762)	17 1/2 (445)	30 (762)	3 (76)
40	2000 (943)	10, 12 (254, 305)	13 (330)	15 1/2 (394)	16 (406)	15 (381)	36 (914)	17 1/2 (445)	32 (813)	4 (101)

FDC8000 Sizes 20 - 60

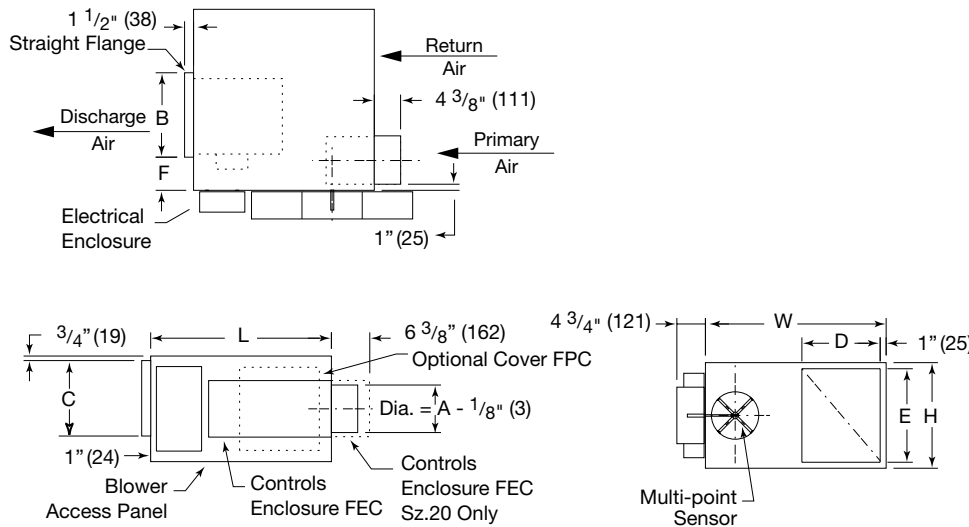

Features:

- Recirculating fan section operates continuously.
- Primary air section controls are pressure independent.
- 22 gauge zinc coated steel housing, mechanically sealed, leak resistant construction.
- Internal insulation, 3/4" (19) dual density, coated to prevent air erosion and meets requirements of UL181 and NFPA-90A.
- Bottom access panel of fan section is easily removable for field service.
- Motor assembly is mounted on vibration isolators. Fan and motor assembly removable as a unit.
- Solid state speed controller for adjusting fan section air flow.
- Units are CSA certified, ETL Listed, ARI Certified.
- Dimensions of control shroud will vary for Series 5000 units depending on the DDC controls supplier.
- A 1 1/2" collar is provided for discharge duct connection.
- Electronic & Pneumatic Controls. Mounted in Toronto.

Call Your Rep.

Size	Capacity (CFM)	
	Primary	Secondary
2006	250-400	250-700
2008	400-700	400-700
3008	550-750	550-1200
3010	800-1200	800-1200
4010	800-1250	800-2000
4012	1000-2000	1000-2000

VMC Vibration Isolators compatible with this Fan:



Hanging Spring

Standing Neoprene

Complete isolator kits are available with spring rubber isolators. The isolators are sized to match the weight of the fan. (Hanging rods supplied by others)



PRICE LGB BY-PASS BOXES:



LGB
By-Pass Box

Control packages available for the LGB By-Pass box:

- EC (2500) Electric Cooling
- EHC (2502) Electric Cooling/ Heating Changeover
- EHC1 (2503) Electric Cooling/ Heating Changeover with 1 Stage Reheat
- PIC (2860) Digital - Cooling Only
- PIC (2863) Digital - Heat/Cool Changeover

Unit Size	Minimum S.P. Airflow		Minimum S.P. Discharge		By-Pass		NCLp Discharge	NCLp Radiated
	L/s	cfm	Pa	in W.G.	Pa	in W.G.		
6	47	100	2	0.01	2	0.01	-	-
	94	200	12	0.05	10	0.04	21	-
	142	300	27	0.11	22	0.09	33	-
	189	400	50	0.22	40	0.16	40	24
8	189	400	17	0.07	32	0.13	25	-
	236	500	25	0.1	50	0.2	31	-
	283	600	37	0.15	72	0.29	39	20
	330	700	50	0.2	97	0.39	40	24
10	236	500	10	0.04	7	0.03	-	-
	330	700	20	0.08	17	0.07	27	-
	425	900	32	0.13	27	0.11	34	-
	519	1100	50	0.2	42	0.17	40	24
12	378	800	12	0.05	24	0.1	21	-
	472	1000	20	0.08	40	0.16	27	-
	614	1300	32	0.13	67	0.27	36	-
	755	1600	50	0.2	100	0.4	40	24
14	519	1100	12	0.05	25	0.1	21	-
	661	1400	20	0.09	40	0.16	28	-
	802	1700	32	0.13	60	0.24	34	-
	991	2100	50	0.2	92	0.37	40	25
16	755	1600	17	0.7	27	0.11	25	-
	944	2000	25	0.1	45	0.18	31	-
	1133	2400	37	0.15	65	0.26	36	23
	1321	2800	50	0.2	87	0.35	40	27

PRICE LBG - BY-PASS BOXES / CONTROL SEQUENCES:

EC (2500) Electric Cooling

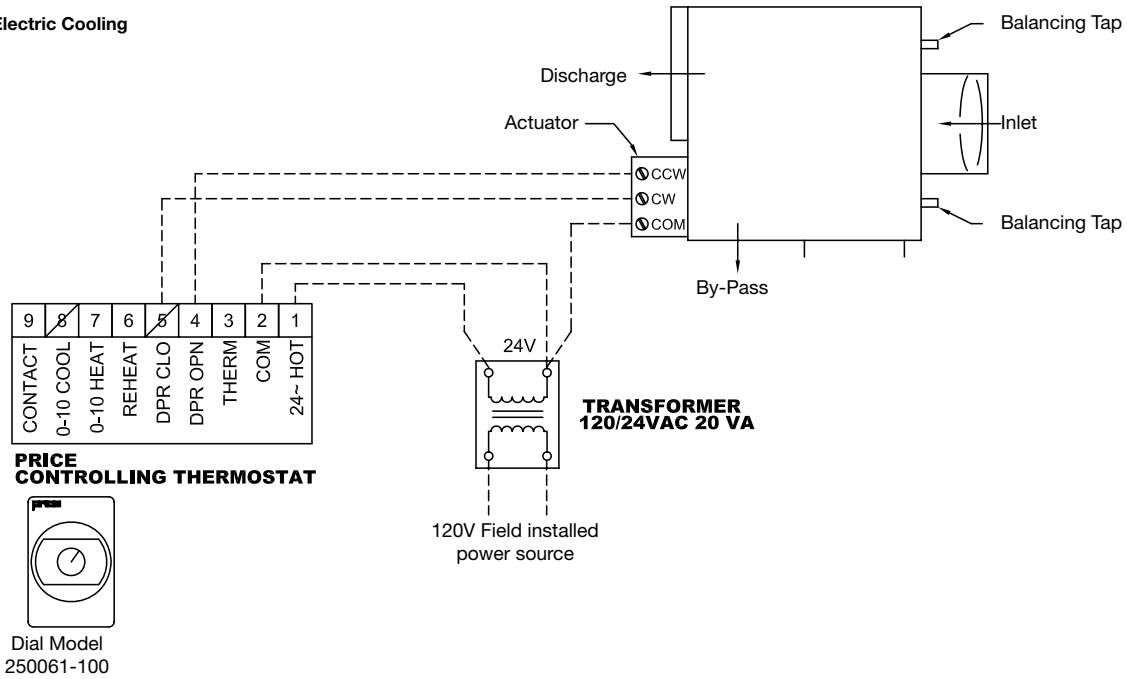

PRICE LGB BY-PASS BOX DIMENSIONS:

Dimensional Data: inches								
Unit Size	Airflow CFM	Inlet Outlet						
		W	L	H	A	B	C	D
6	400	17	17	10	6	9 1/4	9	10
8	600	17	17	10	8	9 1/4	9	10
10	1200	25	25	14	10	11 5/8	13	12 1/2
12	1500	25	25	14	12	11 5/8	13	12 1/2
14	2000	29	29	16	14	14 1/4	15	15
16	2700	33	33	18	16	15 1/8	17	17 1/2

Dimensional Data: mm.								
Unit Size	Airflow CFM	Inlet Outlet						
		W	L	H	A	B	C	D
6	189	432	432	254	152	235	229	254
8	283	432	432	254	203	235	229	254
10	566	635	635	356	254	295	330	318
12	708	635	635	356	305	295	330	318
14	944	737	737	406	356	362	381	381
16	1274	838	838	457	406	384	432	445

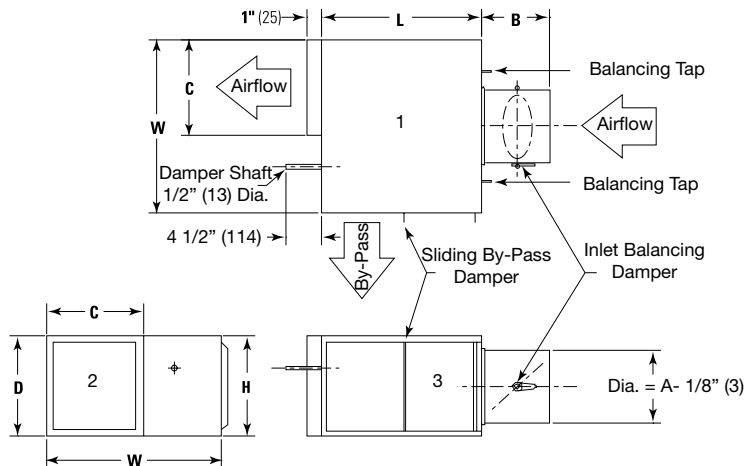

PRICE EHC (2502) ELECTRIC COOLING/ HEATING CHANGEOVER:

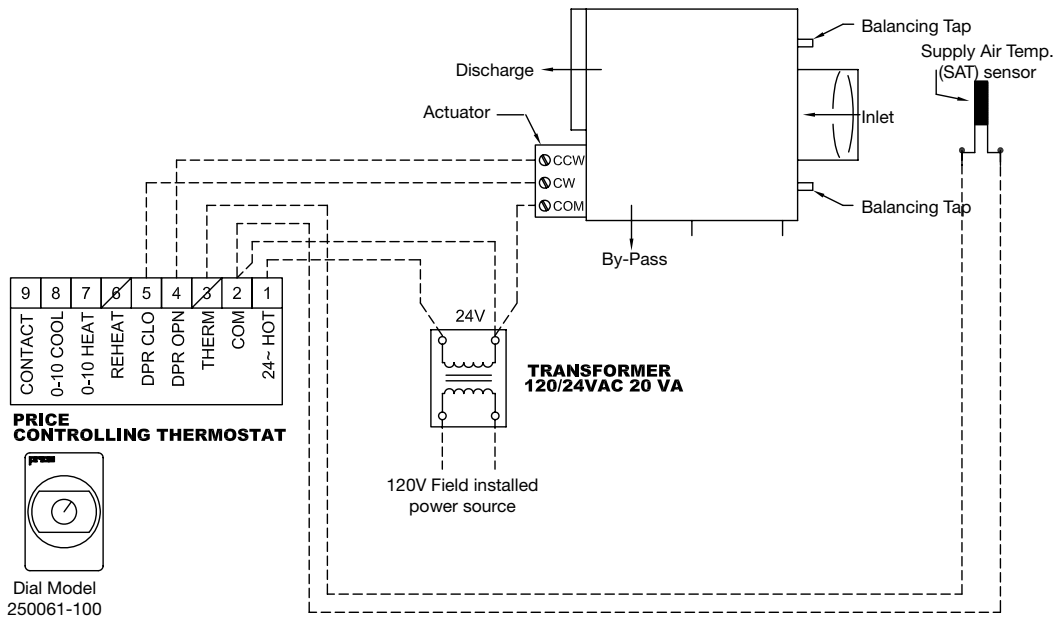

PRICE EHC1 (2503) ELECTRIC COOLING/ HEATING CHANGEOVER WITH 1 STAGE REHEAT:

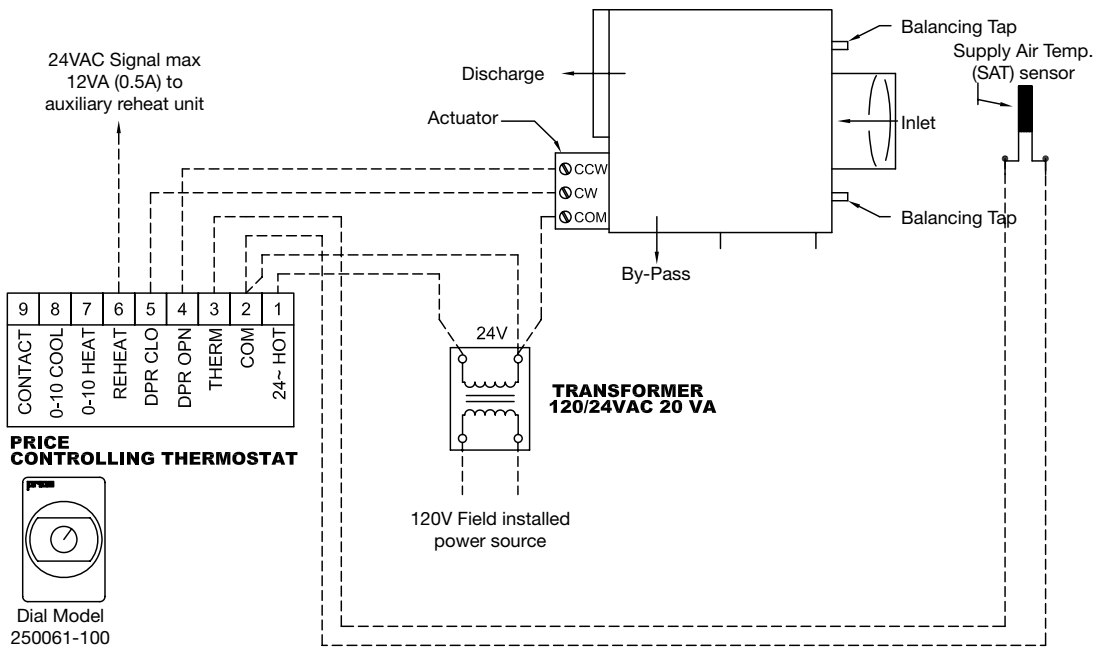

GREENHECK FAN LEGEND:

SP-A50

Nominal CFM at 0.10 inches static pressure
Level of Construction
 A - Premium; Lowest Sound, Insulated Housing
 B - Deluxe Unit; Low Sound, Low Profile
 C - Standard Unit; Lowest Profile, Less Expensive
Model
 SP - Silent Partner
 CSP - Cabinet Silent Partner

GREENHECK SP B70 CEILING EXHAUST FANS:

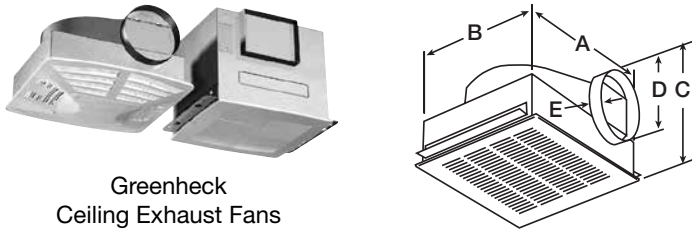

Greenheck Ceiling Exhaust Fans

Performance Data												
Model	RPM	Amps	Watts (Input)	CFM / Static Pressure in inches of W.G.								
					0.000	0.100	0.125	0.250	0.375	0.500	0.625	0.750
SP B70	675	0.53	45.1	CFM	77	71	68	57	49	39	-	-
				Sones	1.2	1.4	1.4	2.0	2.5	3.0	-	-

Dimensional Data: inches									
Model	A	B	C*	D	E	Designer Grille	Decorative Grille	Grille Size	Wt. (kg)
SP-B70	13 ⁷ / ₈	11 ¹ / ₂	7	6	1 ¹ / ₄	14 ⁷ / ₈ x 13 ¹ / ₄	15 ¹ / ₄ sq.	9 ¹ / ₄ x 9	9

For complete dimensional information, see submittal drawings.
 *Add 1¹/₂ in. to C dimension for incandescent light.

GREENHECK SP B90-B200 CEILING EXHAUST FANS:

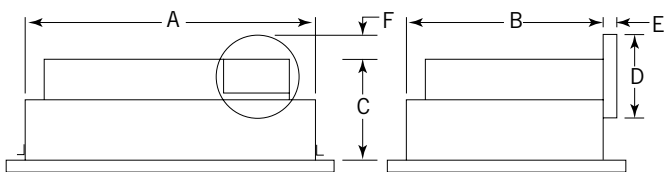

Dimensional Data: inches								
Model	A	B	C	D	E	F	Grille Size	Wt.
B90, B110, B150, B200	13 ⁷ / ₈	11 ¹ / ₂	8 ¹ / ₈	6	1 ¹ / ₄	1 ¹ / ₂	14 ³ / ₄ x 12 ³ / ₄	10

For complete dimensional information, see submittal drawings.

Performance Data												
Model	RPM	Amps	Watts (Input)	CFM / Static Pressure in inches of W.G.								
					0.000	0.100	0.125	0.250	0.375	0.500	0.625	0.750
SP-B90	700	0.65	50	CFM	102	92	88	75	59	45	30	-
				Sones	1.9	2.6	2.7	3.0	3.6	4.1	4.9	-
SP-B110	950	1.14	80	CFM	133	114	110	98	95	95	92	85
				Sones	2.0	2.1	2.2	2.3	2.7	2.7	3.7	4.4
SP-B150	1050	1.70	129	CFM	166	154	153	152	150	150	148	138
				Sones	3.0	3.2	3.3	3.6	4.3	4.5	4.9	5.3
SP-B200	1100	2.20	173	CFM	196	195	194	193	191	190	181	167
				Sones	4.4	4.6	4.7	5.1	5.7	5.8	6.0	6.3

GREENHECK SP-A CEILING EXHAUST FANS:



Greenheck
Ceiling Exhaust Fans

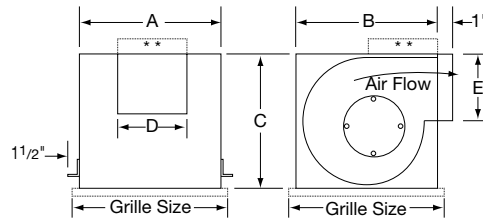

Performance Data												
Model	RPM	Amps	Watts (Input)	CFM / Static Pressure in inches of W.G.								
					0.000	0.100	0.125	0.250	0.375	0.500	0.625	.0750
SP-A110	950	0.58	49	CFM	119	110	106	88	—	—	—	—
				Sones	1.3	1.2	1.2	1.6	—	—	—	—
SP-A125	1100	0.62	53	CFM	135	123	121	104	—	—	—	—
				Sones	1.4	1.7	1.8	1.9	—	—	—	—
SP-A190	1400	1.30	113	CFM	216	197	192	167	133	—	—	—
				Sones	3.2	2.8	2.9	3.1	3.4	—	—	—
SP-A200	900	0.43	48.2	CFM	247	225	220	196	172	142	105	67
				Sones	1.4	2.0	2.0	2.5	3.0	3.5	3.5	4.0
SP-A250	1000	0.77	83	CFM	272	251	246	227	210	185	157	119
				Sones	2.9	3.0	3.0	3.4	4.4	4.6	4.9	5.2
SP-A290	1050	0.72	81	CFM	315	293	287	257	231	207	175	124
				Sones	3.2	3.3	3.3	3.6	3.9	4.1	4.5	5.5
SP-A390	1350	1.34	135	CFM	410	395	391	368	345	325	307	279
				Sones	5.4	5.4	5.4	5.7	6.0	6.3	6.4	6.7
SP-A410	1000	1.74	121	CFM	443	413	405	351	305	109	—	—
				Sones	4.1	3.8	3.7	3.7	4.3	3.7	—	—
SP-A510	1070	3.30	224	CFM	557	512	501	439	392	325	—	—
				Sones	6.0	5.7	5.6	5.5	5.4	4.7	—	—
SP-A710	1080	4.40	285	CFM	752	714	701	653	588	485	320	—
				Sones	7.4	7.2	7.2	7.0	6.8	6.7	6.5	—

Dimensional Data: inches							
Model	A	B	C	D	E	Grille Size	Wt.
A110, A125, A190	13 ³ / ₄	10 ⁵ / ₈	10 ¹ / ₂	8	6	14 ³ / ₄ x 12 ³ / ₄	15
A250, A290, A390	14	11 ⁷ / ₈	11 ¹ / ₂	8	8	14 ³ / ₄ x 12 ³ / ₄	21
A410, A510	18	14 ³ / ₈	14 ¹ / ₂	8	8	19 ³ / ₈ x 16 ³ / ₈	31
A710	18	14 ³ / ₈	14 ¹ / ₂	8	8	19 ³ / ₈ x 16 ³ / ₈	34

For complete dimensional information, see submittal drawings.

GREENHECK SP A900 / A1550 CEILING EXHAUST FANS:



Greenheck
Ceiling Exhaust Fans

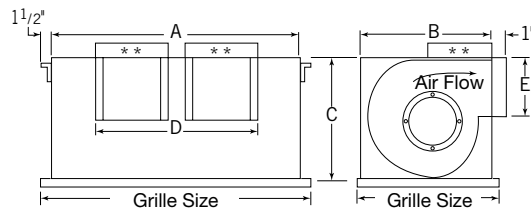

Performance Data												
Model	RPM	Amps	Watts (Input)	CFM / Static Pressure in inches of W.G.								
					0.000	0.100	0.125	0.250	0.375	0.500	0.625	.0750
SP-A900	950	4.00	285	CFM	955	907	896	841	773	701	—	—
				Sones	5.2	5.7	5.8	6.1	6.2	6.2	—	—
SP-A1050	1095	6.30	420	CFM	1125	1058	1043	964	885	796	662	—
				Sones	7.2	7.0	6.9	6.8	6.6	6.5	6.4	—
SP-A1410	1450	7.40	786	CFM	1455	1414	1404	1353	1307	1262	1218	1174
				Sones	11.6	11.6	11.7	11.6	11.5	11.6	11.6	11.6
SP-A1550	1610	8.60	818	CFM	1607	1568	1558	1506	1449	1407	1369	1323
				Sones	12.4	12.1	12.0	12.0	11.9	12.8	14.1	15.9

Dimensional Data: inches							
Model	A	B	C	D	E	Grille Size	Wt.
A900, A1050, A1410, A1550	23 ³ / ₄	14 ³ / ₈	14 ¹ / ₂	18 ³ / ₄	8	25 x 16 ³ / ₈	56

For complete dimensional information, see submittal drawings.

Panasonic WHISPER CEILING SERIES - PANASONIC CEILING MOUNTED VENTILATION FANS:

AVAILABLE TO ORDER



Features:

- Built-in weighted back draft damper
- Low profile, contemporary grille design
- Thermal fuse protection
- Double Hanger Bar for
- Easy Installation
- UL listed for Tub/Shower

Whisper Ceiling Series

Performance Data			
Model	Power (W)	Static Pressure = 0.1	
		CFM	Sones
FV-05VQ3	14	50	<0.3
FV-08VQ3	21	80	0.3
FV-11VQ3	27	110	0.8
FV-20VQ3	42	190	1.3

Dimensional Data				
Fan Size	A	B	C	D
FV-05VQ3	9 ¹ / ₈	7 ¹ / ₈	4	11 ³ / ₁₆
FV-08VQ3	9 ¹ / ₈	7 ¹ / ₈	4	11 ³ / ₁₆
FV-11VQ3	9 ¹ / ₈	7 ¹ / ₈	4	11 ³ / ₁₆
FV-20VQ3	12 ³ / ₁₆	9 ⁹ / ₃₂	6	15

Performance Notes:

1. Static Pressure is shown in inches of water.

GREENHECK CSP A110 / A780 CEILING EXHAUST FANS:



CSP A110
Ceiling Exhaust Fan

Performance Data												
Model	RPM	Amps	Watts (Input)	CFM / Static Pressure in inches of W.G.								
					0.000	0.100	0.125	0.250	0.375	0.500	0.625	.0750
CSP-A110	950	0.62	51	CFM	125	110	102	77	—	—	—	—
				Sones	1.1	1.1	1.3	1.3	—	—	—	—
CSP-A190	1400	1.10	100	CFM	215	202	198	180	159	—	—	—
				Sones	2.3	2.0	2.2	2.7	2.9	—	—	—
CSP-A200	900	0.43	48	CFM	254	230	225	203	177	145	109	70
				Sones	0.8	0.7	0.8	1.3	1.5	1.9	2.2	2.1
CSP-A250	1000	0.79	83	CFM	266	246	241	221	205	187	165	132
				Sones	1.3	1.5	1.5	2.3	3.3	3.4	3.2	3.0
CSP-A290	1050	0.71	80	CFM	318	299	292	265	248	229	201	144
				Sones	1.6	1.7	1.8	2.6	3.3	4.0	3.7	3.4
CSP-A390	1350	1.33	144	CFM	412	400	397	382	363	339	324	309
				Sones	2.8	2.7	2.8	3.2	3.7	4.7	5.5	6.5
CSP-A410	1000	1.87	139	CFM	447	411	403	364	316	217	—	—
				Sones	2.2	2.1	2.2	2.5	2.7	2.7	—	—
CSP-A510	1070	3.11	217	CFM	545	514	506	464	405	324	—	—
				Sones	3.1	2.9	2.8	2.8	2.7	3.1	—	—
CSP-A700	1100	3.2	350	CFM	766	755	752	739	726	702	678	635
				Sones	—	—	—	—	—	—	—	—
CSP-A710	1080	4.40	325	CFM	325	737	698	688	635	566	474	334
				Sones	3.2	3.3	3.2	3.3	2.7	2.5	2.7	—
CSP-A780	1600	3.77	405	CFM	3.2	3.3	3.2	3.3	2.7	2.5	2.7	—
				Sones	813	783	776	741	707	671	637	603

Dimensional Data: inches						
Model	A	B	C	D	E	Wt. (kg)
A190	13 ³ / ₄	10 ⁵ / ₈	10 ¹ / ₂	8	6	16
A200, A250, A290, A390	14	11 ⁷ / ₈	11 ¹ / ₄	8	8	23
A410, A510	18	14 ³ / ₈	14 ¹ / ₂	8	8	36
A700	23 ⁵ / ₈	11 ⁵ / ₈	11 ⁵ / ₈	19 ¹ / ₂	8	34
A710, A780	18	14 ³ / ₈	14 ¹ / ₂	10	8	36

For complete dimensional information, see submittal drawings.

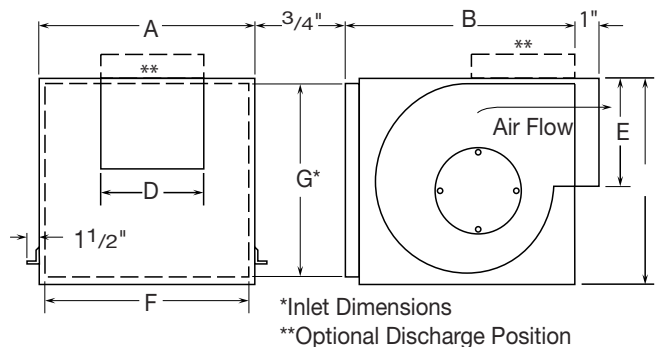

GREENHECK CSP A900 / A1750 CABINET EXHAUST FANS:



**CSP A
Cabinet Exhaust Fan**

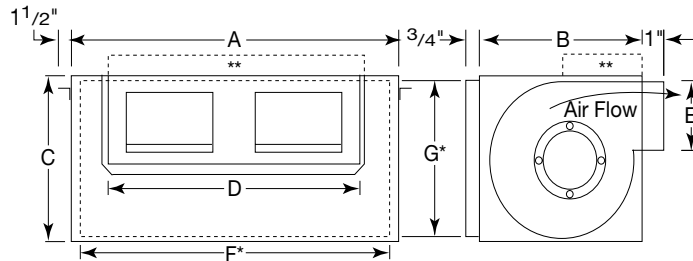

*Inlet Dimensions **Optional Discharge Position

Performance Data												
Model	RPM	Amps	Watts (Input)		CFM / Static Pressure in inches of W.G.							
					0.000	0.100	0.125	0.250	0.375	0.500	0.625	0.750
CSP-A900	950	4.87	328	CFM	908	852	840	782	714	631	—	—
				Sones	3.7	3.8	3.8	4.0	4.0	4.1	—	—
CSP-A1050	1095	6.65	455	CFM	1182	110	1093	1013	922	832	743	—
				Sones	6.3	6.1	5.9	5.8	6.0	6.0	5.5	—
CSP-A1410	1450	7.80	822	CFM	1584	1543	1533	1483	1439	1395	1345	1293
				Sones	6.3	6.2	6.2	6.3	6.5	6.8	7.2	7.6
CSP-A1550	1610	8.32	830	CFM	1672	1617	1604	1542	1484	1427	1367	1306
				Sones	8.6	8.2	8.5	8.4	8.5	8.5	8.5	8.5

Performance Notes:

Performance shown is for Model CSP inline installation type B: free inlet, ducted outlet. Performance ratings include the effects of an inlet duct and backdraft damper in the airstream. Speed (RPM) shown is nominal. Performance is based on actual speed of test.

The sound ratings shown are loudness values in fan sones at 5 ft. (1.5m) in a hemispherical free field calculated per AMCA Standard 301. Values are for installation type B: free inlet sone levels. The AMCA Certified Ratings Sound Seal applies to sone ratings only.

Dimensional Data: inches								
Model	A	B	C	D	E	F	G	Wt.
A900, A1050, A1410, A1550	23 ³ / ₄	14 ³ / ₈	14 ¹ / ₂	18 ³ / ₄	8	22 ⁵ / ₈	13 ¹ / ₄	59
A1750	35	14 ³ / ₄	14 ³ / ₄	28	6	32 ³ / ₄	13	68

For complete dimensional information, see submittal drawings.

GREENHECK WC ROUND WALL CAP:

Dimensional Data: inches					
Model	A	B	C	D	E
WC4	4	5	6	6.5	2.75
WC6	6	5	8	8	4.125
WC8	8	3.5	11	11	5.125

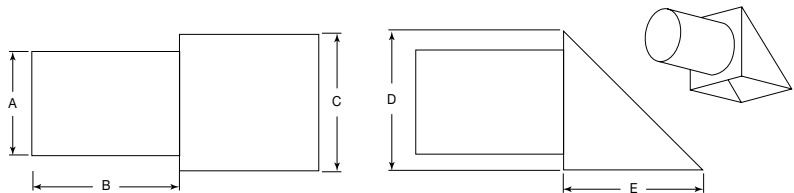

For complete dimensional information, see submittal drawings.

GREENHECK SP & CSP ACCESSORIES:

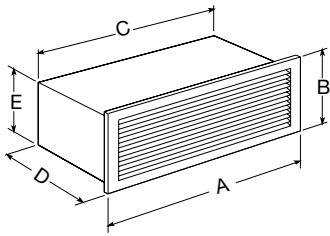

WL

Wall Louvered Discharge

Wall Louvered Discharge features:

- Anodized aluminium grille
- Build in damper
- Not recommended for exterior applications exposed to severe weather conditions. An external wall louver is recommended for such applications.

Model	For use with sizes	A	B	C	D	E
WL-10x3	5-226	12	5 ¹ / ₄	10	7 ³ / ₄	3 ¹ / ₂
WL-18X6	228-265	19 ³ / ₄	8	18	9	6

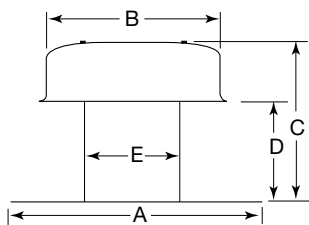

RFC-7

RFC-7 features:

- Weathertight aluminium construction
- Integral birdscreen
- Built in flashing flange

Model	For use with sizes	A	B	C	D	Throat Dia.
RFC-7	5-228	18	12	10	6 ³ / ₈	7

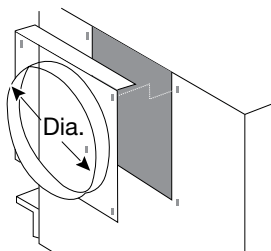

RDC

Round Duct Connector

Round Duct Connector features:

- Replaces the standard square discharge duct-connector and damper
- Uses existing mounting holes
- Galvanized steel construction
- RDC does not include a damper

Model	For use with sizes	Dia.
RDC-6	210-218	6
RDC-8	224-252	8

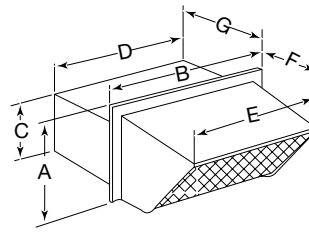

WC

10 x 3 Hooded Wall Cap

Hooded Wall Cap features:

- Steel construction with black enamel finish
- For outside wall applications
- Built in birdscreen and damper

Model	For use with sizes	A	B	C	D	E	F	G
WC-10x3	5-226	5 ¹ / ₂	12 ³ / ₄	3 ¹ / ₂	10 ¹ / ₄	11 ¹ / ₈	4 ¹ / ₄	5

SSC Speed Control
5.0W SSC

For application up to 5 amps (required 2 x 4 handy box by others)

10W SSC

For applications up to 10 amps (requires 4 x 4 handy box by others)

- Time Delay Switch - Model GTD
- MS16
- Reverse Acting T-Stat
- 7 Day Programmable Timer

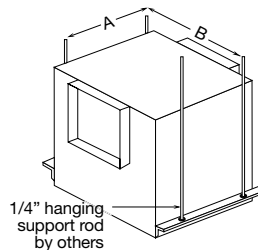

CK

Hanging Vibration Isolators

Hanging Vibration Isolator features:

Vibration isolator kits are available for suspended installations. Kits include all hardware necessary to mount one unit, with the exception of 1/4" threaded rod supplied by others. Fan mounting brackets include pre-punched holes for ease of installation.

Unit Sizes	B110-200	A100-190	A250-390	A410-780	A900-1500	A1750
A	4 ¹ / ₂	5 ¹ / ₂	6 ³ / ₄	9 ¹ / ₄	9 ¹ / ₄	9 ¹ / ₄
B	11 ⁵ / ₈	14 ⁵ / ₈	15 ¹ / ₂	19 ⁵ / ₈	25 ³ / ₈	36 ³ / ₄

GREENHECK G - DIRECT DRIVE CENTRIFUGAL ROOF EXHAUSTERS:

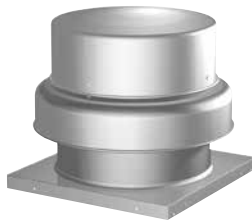

Greenheck Roof Exhausters

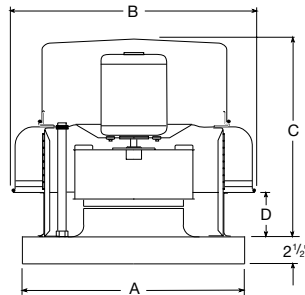

AMCA CERTIFIED RATINGS

SOUND AND AIR PERFORMANCE

AIR MOVEMENT AND CONTROL ASSOCIATION, INC.

Greenheck Fan Corporation certifies that the GB models shown herein are licensed to bear the AMCA Seal. The ratings shown are based on tests made in accordance with AMCA Standard 210 and AMCA Standard 300 and comply with the requirements of the AMCA Certified Ratings program. The sound ratings shown were obtained in accordance with AMCA Standard 300 fig. 2. Loudness values in sones at a distance of 5 feet were calculated in accordance with AMCA Standard 301. The AMCA Certified Ratings Sound Seal applies to some ratings only.

Dimensional Data: inches					
Model	A	B	C*	WD-100 Damper	Roof Opening
G-065, 070, 075	17	19 ³ / ₈	12 ¹ / ₈	8	10 ¹ / ₂
G-080, 085, 090, 095	17	21 ³ / ₄	14 ⁵ / ₈	10	12 ¹ / ₂

*May vary depending on motor size

See page 30 for Performance Data

Model G

Model G direct drive exhausters are designed for roof mounted applications exhausting relatively clean and cool air. They feature a spun aluminium housing, a non overloading backward inclined wheel, and positive motor cooling. Model G fans are licensed to bear the AMCA Certified Ratings Seals for air and sound performance and are

U.L. Listed and CSA certified.

Accessories

- Roof curbs.
- Backdraft damper. Model WD-100, gravity or motorized.
- Speed controls.
- Curbs Available - GPI 17

GREENHECK GB - BELT DRIVE CENTRIFUGAL ROOF EXHAUSTERS:

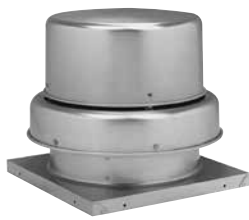

Greenheck Roof Exhausters

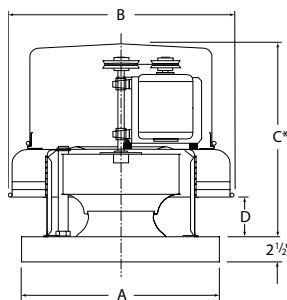

AMCA CERTIFIED RATINGS

SOUND AND AIR PERFORMANCE

AIR MOVEMENT AND CONTROL ASSOCIATION, INC.

Greenheck Fan Corporation certifies that the GB models shown herein are licensed to bear the AMCA Seal. The ratings shown are based on tests made in accordance with AMCA Standard 210 and AMCA Standard 300 and comply with the requirements of the AMCA Certified Ratings program. The sound ratings shown were obtained in accordance with AMCA Standard 300 fig. 2. Loudness values in sones at a distance of 5 feet were calculated in accordance with AMCA Standard 301. The AMCA Certified Ratings Sound Seal applies to some ratings only.

Dimensional Data: inches					
Model	A	B	C*	WD-100 Damper	Roof Opening
GB-071, 081, 091	19	24 ³ / ₈	23 ³ / ₄	12	14 ¹ / ₂
GB-101, 121	19	24 ³ / ₈	23 ³ / ₄	12	14 ¹ / ₂
†GB-131	19	28 ³ / ₈	23 ³ / ₄	12	18 ¹ / ₂
GB-141	22	28 ³ / ₈	23 ³ / ₄	16	18 ¹ / ₂
GB-161	22	28 ³ / ₈	23 ³ / ₄	16	18 ¹ / ₂
†GB-180	30	35 ¹ / ₂	28	18	20 ¹ / ₂
†GB-200	30	35 ¹ / ₂	28	18	20 ¹ / ₂

*May vary depending on motor size

†Units stocked less motors, drives and disconnects. Contact your Price Rep for available Motor / Drive options.

See page 31 for Performance Data

Model GB

Model GB belt drive exhausters are designed for roof mounted applications exhausting relatively clean air. They feature a spun aluminium housing and non-overloading backward inclined wheel. Motors are located out of the airstream with positive cooling by ambient air. Model GB fans are licensed to bear the AMCA Certified Ratings Seals for air and sound performance and are U.L. Listed and CSA certified. Units complete with birdscreen, Disconnect switch.

Dampers Available

- 10 x 10 Damper
- 12 x 12 Damper
- 16 x 16 Damper
- 18 x 18 Damper
- 24 x 24 Damper

GPI's Available

- 17
- 19
- 22
- 30
- 34

Accessories

- Roof curbs.
- Backdraft damper. Model WD-100, gravity or motorized.

GREENHECK G - DIRECT DRIVE CENTRIFUGAL ROOF EXHAUSTERS:



Performance Data												
Model Category	Model	HP	RPM	TS	Static Pressure / Capacity							
						0.000	0.100	0.125	0.250	0.375	0.500	0.625
G-065	G-065-E	1/100	1050	2235	CFM	187	139	110				
					Sones	2.2	2.0	2.0				
					BHP	0.006	0.007	0.007				
	G-065-G	1/60	1300	2765	CFM	231	189	178	91			
					Sones	3.2	3.0	2.9	2.7			
					BHP	0.011	0.012	0.013	0.012			
	G-065-D	1/30	1550	3297	CFM	276	241	232	176	96		
					Sones	4.8	4.4	4.3	4.0	4.0		
					BHP	0.019	0.019	0.020	0.022	0.020		
G-070	G-070-G	1/60	1300	2765	CFM	314	268	257	171			
					Sones	4.1	3.4	3.2	2.7			
					BHP	0.013	0.015	0.015	0.015			
	G-070-D	1/30	1550	3297	CFM	374	337	327	274	190		
					Sones	5.6	5.3	5.2	4.7	4.2		
					BHP	0.022	0.024	0.024	0.026	0.025		
	G-070-E	1/80	1050	234	CFM	396	222	200				
					Sones	3.3	2.8	2.7				
					BHP	0.010	0.011	0.011				
G-080	G-075-G	1/50	1300	2765	CFM	367	309	294	195			
					Sones	4.4	3.8	3.7	3.6			
					BHP	0.019	0.020	0.021	0.020			
	G-075-D	1/25	1550	3297	CFM	439	389	377	310	214		
					Sones	6.1	5.5	5.4	5.3	4.5		
					BHP	0.033	0.034	0.035	0.035	0.033		
G-080	G-080-E	1/40	1050	2990	CFM	335	268	249	134			
					Sones	38	3.6	3.6	3.5			
					BHP	0.012	0.015	0.016	0.017			
	G-080-G	1/30	1300	3701	CFM	415	361	348	272	175		
					Sones	5.4	5.4	5.4	5.4	5.4		
					BHP	0.022	0.026	0.027	0.032	0.033		
	G-080-D	1/20	1550	4413	CFM	495	450	439	379	314	238	
					Sones	7.3	7.4	7.4	7.4	7.4	7.4	7.4
					BHP	0.038	0.042	0.044	0.050	0.055	0.057	
G-085	G-085-E	1/40	1050	2990	CFM	399	326	307	179			
					Sones	3.6	3.7	3.7	3.8			
					BHP	0.012	0.016	0.017	0.019			
	G-085-G	1/30	1300	3701	CFM	494	436	421	340	233		
					Sones	5.4	5.3	5.3	5.2	4.9		
					BHP	0.023	0.028	0.029	0.035	0.036		
	G-085-D	1/20	1500	4413	CFM	588	541	529	464	393	306	169
					Sones	7.5	7.4	7.4	7.4	7.5	7.6	7.7
					BHP	0.039	0.044	0.046	0.053	0.060	0.062	0.056
G-090	G-090-E	1/40	1050	2990	CFM	520	441	420	292			
					Sones	3.6	3.7	3.7	3.6			
					BHP	0.014	0.019	0.020	0.024			
	G-090-G	1/25	1300	3701	CFM	644	580	564	478	373		
					Sones	5.4	5.4	5.4	5.5	5.5		
					BHP	0.027	0.033	0.034	0.041	0.045		
	G-090-D	1/15	1550	4413	CFM	768	714	700	633	558	472	338
					Sones	7.5	7.4	7.4	7.4	7.4	7.4	7.4
					BHP	0.046	0.053	0.055	0.063	0.070	0.076	0.074
G-095	G-095-E	1/30	1050	2990	CFM	717	605	569	389			
					Sones	4.9	4.6	4.6	4.5			
					BHP	0.029	0.034	0.035	0.037			
	G-095-G	1/12	1300	3701	CFM	888	801	780	640	493	184	
					Sones	7.4	6.9	6.8	6.5	6.4	6.4	
					BHP	0.058	0.061	0.063	0.069	0.071	0.049	
	G-095-D	1/8	1500	4413	CFM	1059	986	969	863	745	623	474
					Sones	9.6	9.4	9.4	9.1	8.2	8.0	8.0
					BHP	0.095	0.101	0.103	0.111	0.117	0.120	0.114

GREENHECK GB - BELT DRIVE CENTRIFUGAL ROOF EXHAUSTERS:



Performance Data														
Model	HP	Range	RPM	TS	Sones	Max BHP	Performance in inches							
							0.000	0.125	0.250	0.375	0.500	0.750	1.000	1.250
GB-081-4	1/4	R1	630	1845	2.4	0.009	316	207						
		R1, R2	939	2750	4.7	0.031	470	404	330					
		R2, R3	1247	3652	7.6	0.073	625	575	525	470	403			
		R3	1556	4558	10.8	0.14	779	740	700	660	615	517	120	
		R3	1710	5009	12.5	0.19	856	821	785	748	710	630	511	424
GB-091-4	1/4	R1	630	1845	2.9	0.013	477	309						
		R1, R2	939	2750	5.7	0.042	711	606	490					
		R2, R3	1247	3652	9.2	0.098	945	866	785	698	604			
		R3	1556	4558	11.8	0.19	1179	1116	1052	988	919	772	504	
		R3	1710	5009	13.4	0.25	1296	1238	1180	1122	1062	934	785	685
GB-101-4	1/4	R3	830	2417	4.5	0.033	703	593	420					
		R3	1165	3393	6.8	0.091	987	905	830	731	578			
		R3, R4	1400	4077	8.9	0.16	1186	1117	1051	989	909	810	633	
		R4	1635	4761	11.1	0.25	1385	1325	1269	1214	1161	1094	1019	792
	1/3	R4	1800	5242	13.2	0.33	1525	1471	1418	1367	1320	1270	1208	1064
GB-121-4	1/4		595	2035	3.3	0.021	722	542						
			820	2804	5.2	0.054	995	877	728					
			1045	3574	7.3	0.111	1268	1177	1078	962	805			
			1395	4770	12.5	0.25	1692	1625	1557	1484	1404	1315	1214	907
	1/3		1550	5300	14.6	0.33	1880	1820	1759	1696	1629	1555	1475	1289
1/2		1725	5899	17.4	0.5	2093	2038	1984	1928	1871	1810	1743	1600	
GB-131	1/4		540	1856	4.2	0.018	766	540						
			720	2474	5.4	0.043	1022	879	650					
			960	3299	7.6	0.103	1362	1262	1144	990				
			1315	4518	13.2	0.26	1866	1794	1718	1637	1545	1435	1305	
	1/3		1440	4948	15	0.35	2044	1978	1911	1838	1759	1674	1571	1299
1/2		1685	5790	16.9	0.56	2391	2335	2279	2219	2158	2093	2020	1857	
GB-141-5	1/4		450	1722	3.9	0.017	834	426						
			710	2718	5.7	0.074	1317	1147	908					
			920	3522	7.7	0.16	1706	1576	1439	1258	961			
			1075	4115	10	0.26	1994	1881	1771	1646	1489	1256		
	1/3		1170	4479	11.4	0.34	2170	2066	1966	1858	1733	1574	1355	
	1/2		1360	5207	14.6	0.53	2522	2433	2346	2258	2166	2062	1942	1602
	3/4		1545	5915	17.6	0.78	2866	2787	2709	2634	2556	2475	2384	2176
1		1705	6528	20	1.03	3163	3091	3020	2952	2883	2811	2739	2574	
GB-161-5	1/4		425	1849	4.2	0.029	1255	770						
			625	2720	6.4	0.097	1846	1574	1221					
			865	3764	10.6	0.26	2555	2359	2162	1932	1624			
	1/3		945	4113	12.6	0.34	2791	2612	2433	2236	2009	1692		
	1/2		1100	4787	15.3	0.53	3249	3094	2943	2786	2614	2428	2197	
	3/4		1250	5440	17.9	0.79	3692	3556	3421	3288	3149	2997	2838	
1		1375	5984	21	1.05	4062	3938	3815	3694	3571	3444	3304	2073	
GB-180 LMDX	1/4		495	2397	4.3	0.078	1924	1645	1150					
			730	3535	7.4	0.26	2838	2667	2469	2212	1882			
	1/3		810	3923	8.8	0.35	3149	2997	2832	2623	2375	2052		
	1/2		940	4552	12.7	0.55	3655	3526	3387	3234	3052	2843	2600	
	3/4		1055	5109	16.2	0.77	4102	3989	3866	3741	3596	3432	3251	2811
	1		1185	5739	19	1.1	4607	4507	4400	4290	4179	4045	3900	3575
	1 1/2		1335	6465	22	1.54	5191	5102	5010	4912	4814	4715	4599	4343
2		1460	7071	26	1.97	5677	5595	5514	5424	5335	5245	5155	4938	
GB-200 LMDX	1/4		440	2462	6.5	0.103	2434	1975						
			600	3357	8.5	0.26	3320	2984	2637	2088				
	1/3		665	3721	9.6	0.35	3679	3378	3084	2705	2087			
	1/2		770	4308	12.1	0.55	4260	4013	3744	3477	3140	2643		
	3/4		860	4812	14.1	0.77	4759	4548	4289	4068	3810	3504	3085	
	1		965	5400	16.7	1.09	5340	5157	4927	4719	4519	4285	4015	3239
	1 1/2		1090	6099	20	1.57	6031	5870	5681	5473	5301	5123	4924	4449
2		1200	6715	24	2.09	6640	6493	6336	6144	5968	5812	5650	5274	

GREENHECK CUBE - CENTRIFUGAL ROOF EXHAUSTERS BELT DRIVE, UP BLAST:



Greenheck Roof Exhausters

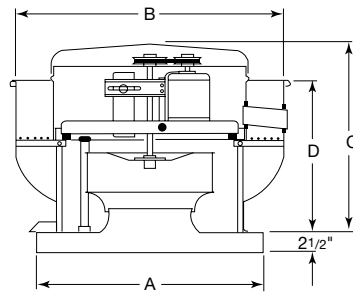

Greenheck Fan Corporation certifies that the GB models shown herein are licensed to bear the AMCA Seal. The ratings shown are based on tests made in accordance with AMCA Standard 210 and AMCA Standard 300 and comply with the requirements of the AMCA Certified Ratings program. The sound ratings shown were obtained in accordance with AMCA Standard 300 fig. 2. Loudness values in sones at a distance of 5 feet were calculated in accordance with AMCA Standard 301. The AMCA Certified Ratings Sound Seal applies to some ratings only.

Dimensional Data: inches				
Model	A	B	C"	Roof Opening
CUBE-101	19	24 ⁷ / ₈	23 ³ / ₄	14 ¹ / ₂
CUBE-121	19	24 ⁷ / ₈	23 ³ / ₄	14 ¹ / ₂
CUBE-141	22	28 ⁷ / ₈	24 ³ / ₄	18 ¹ / ₂
CUBE-180	30	35 ⁷ / ₈	28 ⁵ / ₈	20 ¹ / ₂
CUBE-200	30	35 ⁷ / ₈	28 ⁵ / ₈	20 ¹ / ₂

Model CUBE

Model CUBE is designed for restaurant/commercial kitchen ventilation by exhausting hot and contaminated air up and away from the building.

UL 762 listed for restaurant applications and operation up to 300°F (UL 762 includes UL 705 listing).

Stock Notes:

- The units listed are supplied with 115/60/1 motors installed.
- Units are supplied preset for maximum RPM and are field adjustable.
- For the unit listed, the motor and drive are not included.

Performance Data															
Model	HP	RPM	TS	Static Pressure / Capacity											
					0.000	0.125	0.250	0.375	0.500	0.625	0.750	0.875	1.000		
CUBE-101-4	1/4	1205	3509	CFM	1025	957	872	782	661						
				Sones	77.7	7.6	7.1	6.5	6.2						
				BHP	0.062	0.091	0.097	0.100	0.100						
		1455	4234	CFM	1238	1182	1118	1047	973	893	775				
				Sones	10.4	10.3	10.0	9.6	9.1	8.4	8.1				
				BHP	0.15	0.16	0.16	0.117	0.18	0.18	0.17				
		1660	4834	CFM	1413	1364	1313	1251	1189	1125	1055	974	860		
				Sones	12.7	12.3	12.3	11.6	11.3	10.8	10.2	9.6	9.4		
				BHP	0.22	0.23	0.24	0.25	0.26	0.26	0.26	0.26	0.26	0.25	
CUBE-121-LMD	1/2	1250	4786	CFM	2264	2182	2086	1981	1865	1731	1570	1348			
				Sones	12.7	12.7	12.1	12.1	11.7	11.3	11.4	11.2			
				BHP	0.33	0.34	0.36	0.37	0.37	0.38	0.38	0.36			
		1390	5322	CFM	2517	2445	2361	2270	2173	2068	1949	1817	1642		
				Sones	14.9	14.7	14.2	13.2	12.9	12.5	12.1	11.4	11.0		
				BHP	0.45	0.47	0.48	0.50	0.51	0.51	0.52	0.52	0.51		
		CUBE-141-5	1/2	1250	4786	CFM	2264	2182	2086	1981	1865	1731	1570	1348	
						Sones	12.7	12.7	12.1	12.1	11.7	11.3	11.4	11.2	
						BHP	0.33	0.34	0.36	0.37	0.37	0.38	0.38	0.36	
1390	5322			CFM	2517	2445	2361	2270	2173	2068	1949	1817	1642		
				Sones	14.9	14.7	14.2	13.2	12.9	12.5	12.1	11.4	11.0		
				BHP	0.45	0.47	0.48	0.50	0.51	0.51	0.52	0.52	0.51		
CUBE-180-LMD	3/4			1010	891	CFM	3815	3664	3525	3402	3241	3013	2798	2513	2104
						Sones	15.4	15.2	14.9	14.9	14.7	14.7	13.7	12.6	11.8
						BHP	0.56	0.58	0.61	0.63	0.65	0.65	0.64	0.62	0.58
		1075	5206	CFM	4061	3919	3786	3666	3554	3344	3141	2926	2652		
				Sones	16.5	16.2	15.8	15.7	15.5	15.1	14.7	14.2	13.3		
				BHP	0.67	0.70	0.73	0.75	0.78	0.78	0.78	0.77	0.75		

GREENHECK GPI - PREFAB ROOF CURBS:

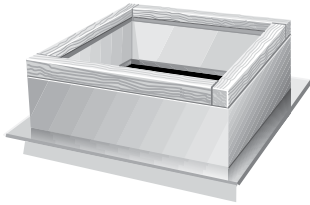

GPI
Prefab Roof Curbs

Model GPI

This curb is designed for roof decks that are covered with 2-6" of insulation. Model GPI is for use on flat roofs. All are mounted directly to the roof deck before the insulation is applied, then roofed and flashed to the top of the wood nailer for weather tightness.

Construction

Models GPI, GPIP and GPIR are available in aluminium (.064) or galvanized steel (18 ga.) and are all welded, with 1" insulation (3# density).

Available Heights

GPI Models: 12"

Damper Installation

When damper trays are specified, mounting holes and attaching devices are provided for installation of backdraft dampers.

Construction

Welded galvanized steel.

GREENHECK VCE - VENTED CURB EXTENSION:

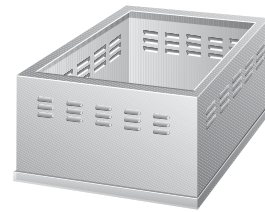

VCE
Vented Curb Extension

Model VCE

The VCE Vented curb extension is designed for use with an 8" high roof curb and the Greenheck Model CUBE Fan to provide the required 40" minimum discharge height above the roof line (per NFPA 96).

Performance Data

Model Curb	Fan Model & Size			Dimensions					
	G	GB	CUBE	Curb Carp. (sq.)	AD (sq.)	B (sq.)	Roof Opening (sq.)	Damper Size (sq.)	Galv. Steel Gauge
GPI-17-G12	060-075			17	15 ¹ / ₂	23 ¹ / ₂	10 ¹ / ₂	8	18
GPI-17-G12	080-095			17	15 ¹ / ₂	23 ¹ / ₂	12 ¹ / ₂	10	18
GPI-19-G12		071-131	101,121,131	19	17 ¹ / ₂	25 ³ / ₄	12 ¹ / ₂	12	18
GPI-22-G12		141,161	141,161	22	20 ¹ / ₂	28 ³ / ₄	14 ¹ / ₂	16	18
GPI-30-G12		180, 200	180, 200	30	28 ¹ / ₂	36 ³ / ₄	20 ¹ / ₂	18	18
GPI-34-G12		220,240		34	32 ¹ / ₂	40 ³ / ₄	26 ¹ / ₂	24	18

Note: GPI curbs must be roofed and flashed to the top of the wooden nailer to assure weather tightness.

Damper Installation

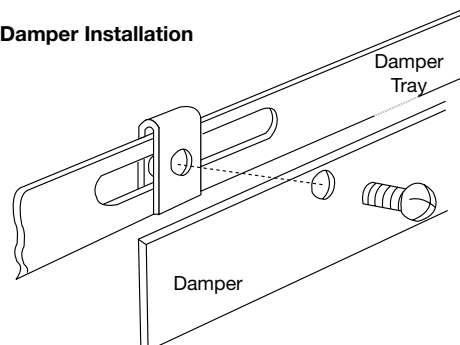

GREENHECK CW - CENTRIFUGAL SIDEWALL EXHAUSTERS DIRECT DRIVE:



Greenheck Centrifugal Sidewall Exhausters

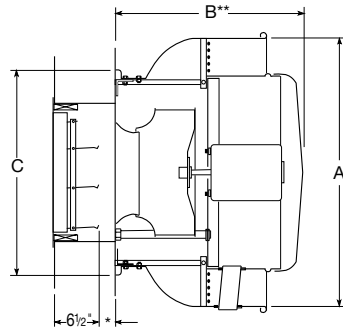

Greenheck Fan Corporation certifies that the GB models shown herein are licensed to bear the AMCA Seal. The ratings shown are based on tests made in accordance with AMCA Standard 210 and AMCA Standard 300 and comply with the requirements of the AMCA Certified Ratings program. The sound ratings shown were obtained in accordance with AMCA Standard 300 fig. 2. Loudness values in sones at a distance of 5 feet were calculated in accordance with AMCA Standard 301. The AMCA Certified Ratings Sound Seal applies to sone ratings only.

Dimensional Data: inches							
Model	A	B	C	Wall Opening	Damper Size	Damper Frame Size	Mtg. Bolt Circle
CW 065-075	18 ³ / ₈	13 ¹ / ₂	14 ³ / ₄	8 ¹ / ₂ x 8 ¹ / ₂	8 x 8	10 x 10	11 ³ / ₄
CW 080-090	21	13 ³ / ₈	17 ⁷ / ₈	10 ¹ / ₂ x 10 ¹ / ₂	10 x 10	12 x 12	15
CW 095	21	15 ¹ / ₄	17 ⁷ / ₈	10 ¹ / ₂ x 10 ¹ / ₂	10 x 10	12 x 12	15
CW 101-121	24 ⁷ / ₈	23 ³ / ₄	19 ³ / ₄	12 ¹ / ₂ x 12 ¹ / ₂	12 x 12	14 x 14	16 ⁷ / ₈
CW 141	28 ⁷ / ₈	24 ³ / ₄	22 ¹ / ₈	15 ¹ / ₂ x 15 ¹ / ₂	15 x 15	17 x 17	19 ³ / ₈

Note: 2 inches minimum, 5 inches when motorized damper is required.

See page 38 for Performance Data

Model CW

The CW models are direct drive centrifugal sidewall exhausters designed to meet the stringent requirements of today's engineers, specifiers, designers, contractors and customers. These units feature "engineered in" performance, efficiency, quietness, rugged construction and lasting quality.

Stock Note:

- The units listed are supplied with 115/60/1 motors installed.
- All stocked CW units can be used with 5W speed control for variable performance requirements.

GREENHECK CW - CENTRIFUGAL SIDEWALL EXHAUSTERS DIRECT DRIVE:



Performance Data												
Model	HP	RPM	TS	Static Pressure / Capacity								
					0.000	0.100	0.125	0.250	0.375	0.500	0.625	
CW-070	CW-070-E	1/100	1050	2234	CFM	250	193	172				
					Sones	2.6	1.6	1.4				
					BHP	0.007	0.008	0.008				
	CW-070-G	1/60	1300	2765	CFM	309	267	255	152			
					Sones	4.0	3.4	3.3	2.4			
					BHP	0.014	0.015	0.015	0.013			
	CW-070-D	1/30	1550	3297	CFM	369	334	325	269	160		
					Sones	5.5	5.2	5.1	4.7	3.9		
					BHP	0.012	0.025	0.025	0.026	0.022		
CW-075	CW-075-E	1/80	1050	2234	CFM	287	210	188				
					Sones	3.4	2.8	2.7				
					BHP	0.012	0.012	0.012				
	CW-075-G	1/50	1300	2765	CFM	356	294	279	185			
					Sones	4.0	3.7	3.7	3.4			
					BHP	0.023	0.023	0.024	0.021			
	CW-075-D	1/25	1550	3297	CFM	424	371	359	291	204		
					Sones	6.0	5.4	5.3	4.9	4.8		
					BHP	0.039	0.039	0.039	0.039	0.035		
CW-080	CW-80-E	1/40	1050	2990	CFM	325	265	248	133			
					Sones	3.8	3.7	3.6	4.2			
					BHP	0.012	0.014	0.015	0.016			
	CW-80-G	1/30	1300	3701	CFM	403	356	343	272	173		
					Sones	5.4	5.4	5.4	5.5	5.9		
					BHP	0.022	0.025	0.026	0.031	0.031		
	CW-80-D	1/20	1550	4413	CFM	481	441	431	376	314	235	
					Sones	7.3	7.4	7.3	7.2	7.3	7.6	
					BHP	0.037	0.041	0.042	0.048	0.052	0.053	
CW-085	CW-85-E	1/40	1050	2990	CFM	389	323	305	182			
					Sones	4.0	3.9	3.9	4.3			
					BHP	0.12	0.16	0.17	0.18			
	CW-85-G	1/30	1300	3701	CFM	481	430	416	340	235		
					Sones	5.4	5.3	5.3	5.3	5.5		
					BHP	0.024	0.027	0.029	0.034	0.035		
	CW-85-D	1/20	1550	4413	CFM	574	532	520	461	395	312	
					Sones	7.5	7.4	7.4	7.4	7.5	7.6	8.1
					BHP	0.040	0.044	0.045	0.052	0.058	0.061	0.051
CW-090	CW-90-E	1/40	1050	2990	CFM	549	470	451	306			
					Sones	4.1	3.9	3.9	4.2			
					BHP	0.019	0.023	0.024	0.027			
	CW-90-G	1/25	1300	3701	CFM	680	616	600	516	391		
					Sones	5.5	5.4	5.4	5.4	5.6		
					BHP	0.035	0.041	0.042	0.048	0.052		
	CW-90-D	1/15	1550	4413	CFM	811	757	744	677	603	501	
					Sones	7.8	7.6	7.6	7.5	7.4	7.4	7.8
					BHP	0.060	0.066	0.068	0.076	0.082	0.087	0.084
CW-099	CW-95-E	1/30	1050	2990	CFM	711	603	570	381			
					Sones	5.3	4.5	4.5	4.5			
					BHP	0.032	0.036	0.037	0.037			
	CW-95-G	1/12	1300	3701	CFM	880	797	774	641	484	199	
					Sones	7.5	6.8	6.7	6.4	6.4	6.8	
					BHP	0.061	0.066	0.067	0.072	0.071	0.054	
	CW-95-D	1/8	1550	4413	CFM	1049	983	964	861	747	616	
					Sones	9.6	9.3	9.3	8.5	8.3	8.1	7.8
					BHP	0.10	0.11	0.12	0.12	0.12	0.12	0.11
CW-101	CW-101-B	1/12	1140	3320	CFM	970	897	806	707			
					Sones	7.2	7.0	6.5	6.0			
					BHP	0.07	0.08	0.08	0.09			
CW-121	CW-121B	1/12	1140	3898	CFM	1346	1261	1180	1091	981	833	
					Sones	7.4	7.9	8.2	8.2	8.0	8.1	
					BHP	0.11	0.12	0.13	0.13	0.14	0.14	
CW-141	CW-141-B	1/12	1140	3898	CFM	1346	1261	1180	1091	981	833	
					Sones	7.4	7.9	8.2	8.2	8.0	8.1	
					BHP	0.11	0.12	0.13	0.13	0.14	0.14	

Performance notes:
Performance shown is for Model CW without ducts.

GREENHECK CWB - CENTRIFUGAL SIDEWALL EXHAUSTERS BELT DRIVE:



Greenheck Centrifugal Sidewall Exhausters

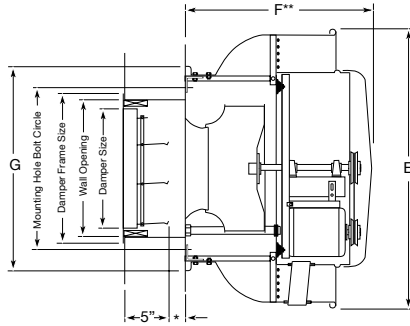

**AMCA
CERTIFIED
RATINGS**

**SOUND
AND
AIR
PERFORMANCE**

Greenheck Fan Corporation certifies that the GB models shown herein are licensed to bear the AMCA Seal. The ratings shown are based on tests made in accordance with AMCA Standard 210 and AMCA Standard 300 and comply with the requirements of the AMCA Certified Ratings program. The sound ratings shown were obtained in accordance with AMCA Standard 300 fig. 2. Loudness values in sones at a distance of 5 feet were calculated in accordance with AMCA Standard 301. The AMCA Certified Ratings Sound Seal applies to sone ratings only.

**AIR
MOVEMENT
AND CONTROL
ASSOCIATION, INC.**
P.O. BOX 12000, CHICAGO, IL 60621

Dimensional Data: inches					
Model	E	F	G	Wall Opening	Damper Size
CWB-141-LMD	28 ⁷ / ₈	24 ³ / ₄	22 ¹ / ₈	14 ¹ / ₂ x 14 ¹ / ₂	15 x 15
CWB-180-LMD	35 ³ / ₈	28 ⁵ / ₈	27 ³ / ₄	18 ¹ / ₂ x 18 ¹ / ₂	17 x 17

* CWB-101, 141, 180 stocked less motor & drives. Contact your Price Rep for available Motor / Drive options.

Model CWB

These fans are ideal for exhausting contaminated air out and away from buildings. Fan wheels shall be centrifugal, backward inclined, and constructed of aluminium.

Model CW Sidewall Exhaust fans are the centrifugal direct drive type.

Model CWB Sidewall Exhaust fans are the centrifugal belt drive type. Adjustable motor pulleys allow for final system balancing.

Performance Data												
Model	HP	Min/Max RPM	Sones at 0 in.	Static Pressure / Capacity								
					0.000	0.125	0.250	0.375	0.500	0.750	1.000	
CWB-141-LMD	1/2	590	5	CFM	1069	851						
				Sones	5.0	4.5						
				BHP	0.04	0.04						
	1	1725	26	CFM	3125	3066	3005	2936	2865	2711	2539	
				Sones	26.0	23.0	22.0	24.0	24.0	15.1	14.3	
				BHP	0.87	0.87	0.90	0.92	0.94	0.97	1.00	
CWB-180-LMD	1/4	630	7.1	CFM	2380	2154	1861					
				Sones	7.1	6.4	15.5					
				BHP	0.13	0.51	0.16					
	2	1495	28	CFM	5648	5546	5443	5254	5082	4598	3983	
				Sones	28.0	27.0	27.0	26.0	25.0	24.0	22.0	
				BHP	1.80	1.84	1.89	1.96	2.02	2.10	2.06	

Performance notes:

1. Performance shown is for Model CWB without ducts.
2. BHP does not include drive losses.

cUL762 Approved for "Power Vent for Restaurant Appliances"

*Note: 2 inches minimum, 5 inches when motorized damper is required.



CWB
Centrifugal Sidewall Exhauster

Dimensional Data: inches					
Model	A	B	C	D	E
SQ70-75	13	12	8 ⁷ / ₈	N/A	1
SQ80-95	16	15	11 ⁷ / ₈	N/A	1

- Vibration Isolation Kits - HSA-1B-35, RD-1-35
- Insulation Kits

Model SQ

Units are stocked with 115/60/1 motors mounted. All can be used with a speed control and offer thermal overload protection. SQ-70 through SQ-95 are equipped with 3 speed motors, field wired for either 1050, 1300 or 1500 RPM.

General

Models SQ and BSQ inline duct fans are designed for intake, exhaust, return or makeup air systems that require high efficiency mounting versatility, low sound levels and ease of service. The square, compact housing design permits mounting in any position, whether horizontal, vertical or at any angle. Two removable panels provide access for service.

Models SQ and BSQ are licensed to bear the AMCA Certified Ratings Seals for Sound and Air Performance. All stock SQ and BSQ sizes are UL listed.

Construction Features

- Galvanized steel housing, aluminium wheel.
- Two removable service panels.
- Formed collars for duct connection at inlet and outlet.
- Flexible motor leads and combination junction box and Disconnect switch (standard).
- c/w insulated housing (optional).
- Disconnect switch



Greenheck Fan Corporation certifies that the GB models shown herein are licensed to bear the AMCA Seal. The ratings shown are based on tests made in accordance with AMCA Standard 210 and AMCA Standard 300 and comply with the requirements of the AMCA Certified Ratings program. The sound ratings shown were obtained in accordance with AMCA Standard 300 fig. 2. Loudness values in sones at a distance of 5 feet were calculated in accordance with AMCA Standard 301. The AMCA Certified Ratings Sound Seal applies to some ratings only.

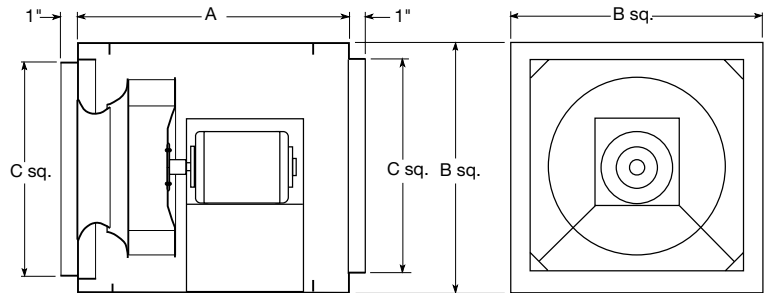

VMC Vibration Isolators compatible with this Fan:



Hanging Spring



Standing Neoprene

Complete isolator kits are available with spring rubber isolators. The isolators are sized to match the weight of the fan. (Hanging rods supplied by others)



THE VMC GROUP
The Power of Together™

GREENHECK SQ - CENTRIFUGAL INLINE FANS DIRECT DRIVE:



SQ
Centrifugal Inline Fan

General

The models SQ and BSQ have square housing designs for indoor applications. Easy access for inspection and service is provided by removable side panels. Capacities range from 50 to 27,000 cfm and up to 4.0 in. wg.

The centrifugal inline fans includes:

- Both direct and belt driven fans with backward-inclined or forward curved wheels
- Models feature rugged constructions
- High-efficiency, and low sound levels
- Centrifugal inline fans are ideal for clean air applications, including intake, exhaust, return, or make-up air

Performance Data												
Model	HP	RPM	TS	Sones at 0 in.	Max BHP	Performance in inches W.G.						
						0	0.1	0.125	0.25	0.375	0.5	0.625
SQ-70-E	¹ / ₁₁₀	1050	2233	2.7	0.010	212	140	118				
SQ-70-G	¹ / ₅₀	1300	2765	4.1	0.020	262	204	190				
SQ-70-D	¹ / ₃₀	1550	3297	5.6	0.030	313	265	252	189			
SQ-75-E	¹ / ₉₀	1050	2233	3.6	0.011	241	167	146				
SQ-75-G	¹ / ₄₅	1300	2765	4.1	0.210	298	239	224	133			
SQ-75-D	¹ / ₂₅	1550	3297	6.1	0.035	356	306	294	229	137		
SQ-80-E	¹ / ₅₀	1050	2989	3.8	0.016	306	241	225	104			
SQ-80-G	¹ / ₃₀	1300	3701	5.4	0.032	378	324	312	244	140		
SQ-80-D	¹ / ₁₅	1550	4412	7.3	0.055	451	405	394	342	280	201	
SQ-85-E	¹ / ₁₄₀	1050	2989	4.0	0.017	357	291	272	142			
SQ-85-G	¹ / ₃₀	1300	3701	5.5	0.033	442	391	377	298	185		
SQ-85-D	¹ / ₁₅	1550	4412	7.6	0.057	528	485	474	413	343	254	
SQ-90-E	¹ / ₅₀	1050	2989	4.0	0.020	500	399	369	188			
SQ-90-G	¹ / ₂₅	1300	3701	5.4	0.040	619	539	519	397	245		
SQ-90-D	¹ / ₁₀	1550	4412	7.6	0.068	738	673	654	564	457	334	
SQ-95-E	¹ / ₃₀	1050	2989	4.9	0.031	623	507	475	274			
SQ-95-G	¹ / ₁₅	1300	3701	7.6	0.059	771	684	659	522	352		
SQ-95-D	¹ / ₈	1550	4412	9.6	0.100	919	852	829	720	603	461	276

GREENHECK BSQ- CENTRIFUGAL INLINE FANS BELT DRIVE:



BSQ
Centrifugal Inline Fans

AMCA CERTIFIED RATINGS

SOUND AND AIR PERFORMANCE

AIR MOVEMENT AND CONTROL ASSOCIATION, INC.

Greenheck Fan Corporation certifies that the GB models shown herein are licensed to bear the AMCA Seal. The ratings shown are based on tests made in accordance with AMCA Standard 210 and AMCA Standard 300 and comply with the requirements of the AMCA Certified Ratings program.

The sound ratings shown were obtained in accordance with AMCA Standard 300 fig. 2. Loudness values in sones at a distance of 5 feet were calculated in accordance with AMCA Standard 301. The AMCA Certified Ratings Sound Seal applies to some ratings only.

Dimensional Data: inches				
Model	A	B	C	D
BSQ80, BSQ90	21	15	11 ⁷ / ₈	9
BSQ100	21	17	13 ⁷ / ₈	9
BSQ120	21	19	15 ⁷ / ₈	9
BSQ140-LMDX	22	23	19 ⁷ / ₈	9

- Vibration Isolation Kits - HSA-1B-35, RD-1-35
- Insulation Kits

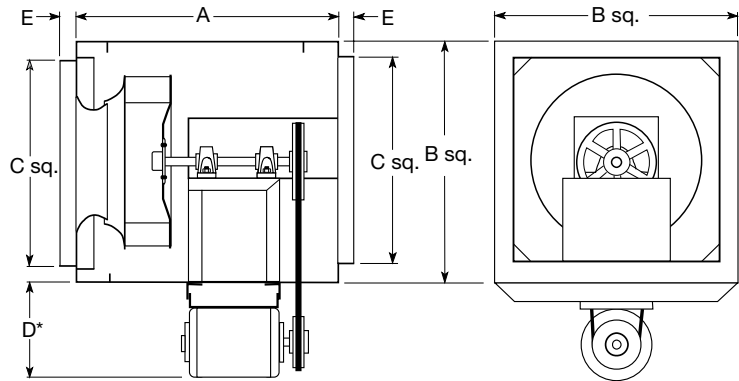

General

Models SQ and BSQ inline duct fans are designed for intake, exhaust, return or makeup air systems that require high efficiency mounting versatility, low sound levels and ease of service. The square, compact housing design permits mounting in any position, whether horizontal, vertical or at any angle. Two removable panels provide access for service. Models SQ and BSQ are licensed to bear the AMCA Certified Ratings Seals for Sound and Air Performance. All stock SQ and BSQ sizes are UL listed.

Construction Features

- Galvanized steel housing, aluminium wheel.
- Galvanized steel housing, aluminium wheel.
- Two removable service panels.
- Formed collars for duct connection at inlet and outlet.
- Flexible motor leads and combination junction box and disconnect switch (standard).
- BSQ motors, bearings and drives are mounted out of the airstream and are cooled by ambient air.
- c/w insulated housing (optional).
- Disconnect switch.

VMC Vibration Isolators compatible with this Fan:



Hanging Spring



Standing Neoprene

Complete isolator kits are available with spring rubber isolators. The isolators are sized to match the weight of the fan. (Hanging rods supplied by others)



THE VMC GROUP
The Power of Together™

GREENHECK BSQ - CENTRIFUGAL INLINE FANS BELT DRIVE:



BSQ
Centrifugal Inline Fan Belt Drive

General

The models SQ and BSQ have square housing designs for indoor applications. Easy access for inspection and service is provided by removable side panels. Capacities range from 50 to 27,000 cfm and up to 4.0 in. wg.

The centrifugal inline fans includes:

- Both direct and belt driven fans with backward-inclined or forward curved wheels
- Models feature rugged constructions
- High-efficiency, and low sound levels
- Centrifugal inline fans are ideal for clean air applications, including intake, exhaust, return, or make-up air

Performance Data										
Model	HP	RPM	Performance in inches W.G.							
			0.125	0.250	0.375	0.500	0.625	0.750	1.00	1.250
BSQ-80-4	1/4	1050	371	297						
		1430	544	499	447	386	322			
		1835	720	687	651	614	571	525	425	
BSQ-90-4	1/4	1050	546	443						
		1440	805	741	669	588	480			
		1695	965	914	858	798	730	654		
BSQ-100-4	1/4	1050	774	671						
		1265	966	983	798	683				
		1610	1266	1207	1149	1089	1004	917		
BSQ-120-4	1/4	1000	1025	913	782					
		1210	1283	1192	1098	992	860			
		1370	1475	1395	1315	1230	1135	1025		
BSQ-140-LMDX	1/4	800	1362	1185	859					
	1/4	1075	1925	1807	1679	1535	1306			
	1/3	1080	2132	2028	1915	1795	1615	1442		
	1/2	1355	2474	2389	2295	2195	2092	1976	1630	
	3/4	1550	2852	2781	2702	2619	2531	2442	2245	1954
	1	1710	3160	3096	3029	2954	2879	2800	2637	2453
	1 1/2	1960	3640	3584	3528	3469	3403	3338	3201	3059
2	2135	3974	3871	3820	3763	3763	3803	3583	3454	

GREENHECK SE1- DIRECT DRIVE SIDEWALL PROPELLER FANS:



Greenheck Direct Drive Fans

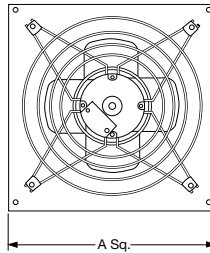
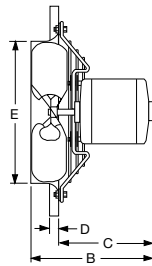

Greenheck Fan Corporation certifies that the SE1 models shown herein are licensed to bear the AMCA Seal. The ratings shown are based on tests made in accordance with AMCA Publication 210 and comply with the requirements of the AMCA Certified Ratings program.

Dimensional Data: inches						
Fan Size	A Panel Sq.	B	C*	D	E	Damper Size Sq.
8	13 ¹ / ₈	7	5	1	8 ³ / ₈	10
12	18 ¹ / ₈	10 ³ / ₄	8 ¹ / ₄	1	12 ³ / ₈	14
18	24 ¹ / ₈	14	10 ⁷ / ₈	1	18 ³ / ₈	20

* Varies with motor selection

Model SE1 Standard Features:

- All SE1 motors have thermal overload protection.
- SE1-8 and 12 are equipped with 3 speed motors, field wired to the selected RPM.
- All stocked SE1 units can be used with a 5w speed control.

Stock Note:

- Units stocked with 115 / 60 / 1 motors.

Performance Data						
Model		RPM	Static Pressure / Capacity			
			0"SP	1/10"SP	1/8"SP	1/4"SP
SE1-8-QD 3 Speed	E	1050	311	126	100	
	G	1350	399	256	198	
	D	1550	459	351	307	167
SE1-12-QD 3 Speed	E	1050	981	744	678	
	G	1350	1262	1097	1037	
	D	1550	1449	1309	1271	1042
SE1-18-B4-QD	B4	1160	3238	2967	2908	2434

Performance notes:

Performance shown is for model SE1 exhaust without ducts.

GREENHECK WD - MOTORIZED OR AUTOMATIC BACKDRAFT DAMPERS:



WD-100

Damper Size Sq.	B	Fan Model & Size		
		G	GB	CUBE
8 x 8	4 ⁵ / ₈	65, 70, 75		
10 x 10	5 ⁵ / ₈	80, 85, 90, 95		
12 x 12	6 ⁵ / ₈			100
16 x 16	6 ³ / ₈			140
18 x 18	5 ³ / ₈		180	180
24 x 24	6 ¹ / ₈		200, 240	

Model WD-100 dampers are designed for use with all Greenheck roof mounted exhaust fans.

Dimension "C": 10" maximum.

* Actual dimension is 1/8" smaller than nominal

WD-320

Damper Size Sq.	Fan Model & Size
10 x 10	SE1-8
14 x 14	SE1-12
20 x 20	SE1-18

* Damper shown with Optional Motors

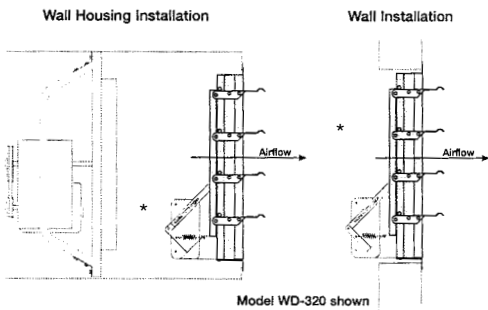

WD-323

Damper Size Sq.	Fan Model & Size CWB
8 x 8	65, 70, 75
10 x 10	80, 85, 90, 95
12 x 12	101
15 x 15	141

Model 323 dampers are designed for vertical mounting and use with Greenheck's centrifugal sidewall exhausters

* Damper shown with Optional Motors

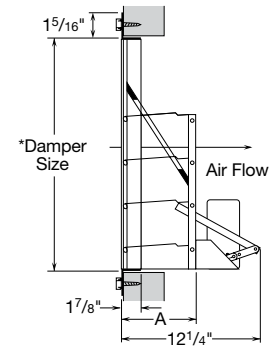

GREENHECK MP-100 / MP-300



MP-100

MP-300

MP-100 motor packs shall be used with all

Note: Use with WD-100 motorized exhaust dampers.

- Motor
- Motor Bracket
- Motor Arm Assembly
- Connecting Link
- Motor Spring

MP-300 motor packs shall be used with all

Note: Use with WD-300 motorized exhaust dampers.

- Motor
- Motor Bracket
- Motor Arm Assembly
- Connecting Link
- Motor Spring

GREENHECK QUICK DELIVERY / KITCHEN VENTILATION - TYPE 1 HOODS:

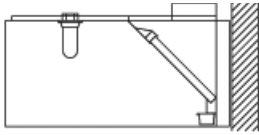

Wall Style (Exhaust Only)

Sizes Available	
Length	36 in. - 192 in.
Width	38 in. - 60 in.
Height	24 in. or 30 in.

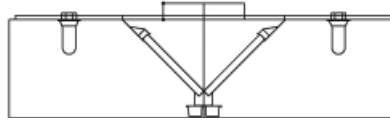

Double Island (Exhaust Only)

Sizes Available	
Length	36 in. - 192 in.
Width	72 in. - 120 in.
Height	24 in. or 30 in.

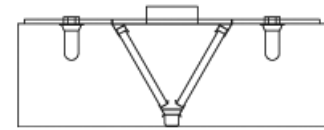

Single Island V-Bank (Exhaust Only)

Sizes Available	
Length	36 in. - 192 in.
Width	48 in. - 78 in.
Height	24 in. or 30 in.

Information below applies to all product shown above

Standard Features:

- UL/cUL Listed and NSF
- Certified 18 Ga. 304 SS or 430 SS construction
- Integral 3 in. airspace for clearance to limited combustibles

Service Chart:

All hoods are available in 5 or 10 days depending upon the accessories chosen. See next:

5 Day Accessories:

- Light/Fan switches, hood or remote mounted
- duct collars shipped loose (factory attached std.)
- Filler panels for clearance to limited combustibles
- Enclosure panels to span between roof and ceiling
- Kitchen fan control center

10 Day Accessories:

- Stainless steel back-splash panel, (non insulated)
- End slots for improved capture and performance
- Insulated supply plenum
- Exhaust air balancing baffle
- Fire cabinet - utility cabinet
- Fire suppression system - full or pre-piped
- Trim strips

GREENHECK ACCESSORIES:



The Grease Grabber

(Stainless Steel) two-stage filtration system is utilized in conjunction with the Grease-X-Tractor to be 80% efficient. UL/cUL 1046 Classified and NSF Certified.



The Grease X-Tractor

High efficiency stainless steel or aluminum filters have twice the grease extraction capability of the baffle filter. The filters shall be UL/cUL 1046 Classified and NSF Certified.



Aluminum or Stainless Steel baffle:

Aluminum or stainless steel baffle type are the traditional choice for inexpensive grease removal. Filters shall be UL/cUL 1046 Classified.



High Velocity Stainless Steel cartridge filters:

The high velocity stainless steel cartridge filters offer dry cartridge performance with lower cost. The filters shall be UL/cUL 1046 Classified and NSF Certified.



Supply Plenums Internal



Supply Plenums External

Face supply hood(s) full with compensating model with the capability to replace exhausted air with outside air.



Back Supply Plenum



Variable Supply Plenum

Air Curtain Supply Plenum

Introduces air in a downward pattern that contains contaminated air while providing cooling to the cooks.

Back Supply Plenum:

Introduces air below and behind the cooking equipment, allowing air to rise and mix with room air.

Variable Supply Plenum:

Distributes air out into the kitchen through the face and/or introduces air down onto cooking personnel through the curtain.

GREENHECK QUICK DELIVERY / KITCHEN VENTILATION:



GD1

Condensate Hood, No baffles.

The GD1 Hood is designed for light condensate applications. The lack of baffles means the duct collar can be freely positioned - a design plus.



GD2

Condensate Hood, 1 baffle.

The GD2 Hood is designed for moderate condensate applications. The one baffle means the duct collar position can be adjusted.



GD3

Condensate Hood, 2 baffles.

The GD3 Hood is designed for heavy condensate applications. The 2 baffles catch and drain all moisture - no drips.



GDO

Oven Hood

The GDO Hood is designed to capture heat and vapor, creating a more comfortable environment for the cooking staff.

GREENHECK QUICK DELIVERY / KITCHEN VENTILATION:



ERV

Energy Recovery Ventilators

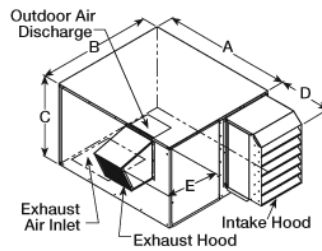

Greenheck Fan Corporation certifies that the ERV models shown here are licensed to bear the AMCA Seal. The ratings shown are based on tests made in accordance with AMCA Standard 211 and comply with the requirements of the AMCA Certified Ratings Program.

General:

Energy Recovery Ventilators pre-condition outdoor air to near room conditions. Fresh outdoor air flows through one side of the unit, while stale exhaust air from the building flows through the other side. An energy recovery wheel rotates between the two airstreams, transferring temperature and moisture properties. In the summer, this transfer reduces the temperature and moisture level of the outdoor air. Likewise in the winter, this transfer increases the temperature and moisture of the outdoor air. The overall effect is a significant reduction in the amount of energy used to condition the outdoor air. All ERV models can be roof mounted or mounted indoors for clean air applications up to 130°F. Energy recovery ventilators are primarily used in institutional and commercial air conditioned applications.

Performance:

Performance capabilities 500 cfm to 6000 cfm and up to 11/2 in. wg. of external static pressure

Model	Exterior Dimensions					Weight (lbs.)	Curb Outside Dimensions
	A	B	C	D	E		
ERV-251	46	34	27	12	8	340	42 1/2 x 30 1/2
ERV-361	62	51	34	18	15	860	58 1/2 x 47 1/2
ERV-521	67	67	44	16	15	1290	63 1/2 x 63 1/2
ERV-581	75	70	67	16	22	1470	71 3/4 x 66

Standard Construction Features:

- Galvanized steel construction
- AMCA Certified Air Performance
- Total enthalpy wheel certified to ARI Standard 1060
- 1 in. foil face insulation
- Forward curved blowers
- Single Point wiring
- Motor starters
- Non-fused disconnect

Options and Accessories:

- Fresh air & exhaust air filters, 2 in. pleated (30% efficiency)
- Supply & exhaust dampers
- Roof curbs
- Listed to UL-1995 (open motors only)
- Enthalpy sensor (Economizer)
- Temperature sensor (Economizer)
- Timed exhaust frost control
- Duct flanges
- Hinged access doors (361,521,581 only)
- Weatherhood
- Dirty filter sensor
- Service outlet
- Permatector

Benefits for Building Occupants and Owners:

- Humidity control
- Reduced latent load on air conditioning equipment improved indoor air quality of building
- Increased comfort of building occupants
- Reduced ventilation costs by as much as 75% producing year round energy savings
- Eliminates problems associated with high indoor moisture levels

Benefits for Building Occupants and Owners:

Energy recovery technology is well suited for commercial and institutional applications such as classrooms, offices, meeting rooms, condominiums and assisted living facilities.

GREENHECK QUICK DELIVERY / ENERGY RECOVERY:

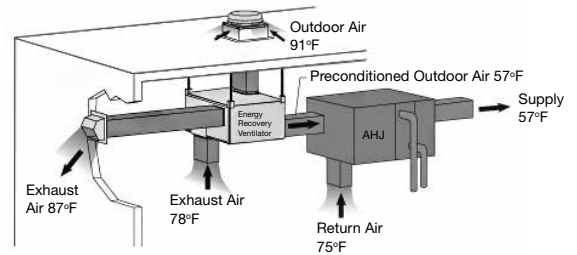
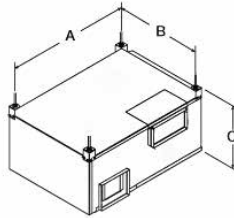

ERV
Energy Recovery Ventilations

Model	Exterior Dimensions			Weight (lbs.)
	A	B	C	
450	46	29	20	156
750	48	36	22	210

Service and Maintenance:

ERVs are engineered for minimal maintenance and have numerous panels for easy access to internal components requiring maintenance. Outdoor air and exhaust airstreams typically have throwaway filters that need to be replaced on a regular schedule. The energy wheel is segmented and slides out to allow personnel to transport the wheel segments to a convenient location for cleaning. While the wheel should be checked annually, cleaning is required only once every 2-3 years, and mild detergent and water is all that is required.

MiniVent 450 & 750:

The MiniVent is an energy recovery ventilator for commercial and institutional applications that require 300 cfm to 800 cfm of ventilation air. The compact design provides an economical solution for individual spaces, such as school classrooms and small offices.

The MiniVent is designed for indoor installations and may be floor mounted or ceiling hung. A removable panel enables easy access to filters and enthalpy wheel.

Standard Construction Features:

- Galvanized steel construction
- Total enthalpy wheel certified to ARI Standard 1060
- Forward curved blower
- Single point wiring
- 1 in. pleated filters
- Insulated
- Listed to UL-1995

Accessories:

- Intake and exhaust accessories GRS and GRSF
- Wall mount accessories BV-Brick Vent and WC-Wall Cap
- Speed control
- Motion detector (miniVent 450 only)
- Hanging vibration isolator kits

Performance:

Performance capabilities 300 cfm to 800 cfm and 1 in.wg. of external static pressure.

VMC Vibration Isolators compatible with this Fan:



Hanging Spring

Complete isolator kits are available with spring rubber isolators. The isolators are sized to match the weight of the fan. (Hanging rods supplied by others)



GREENHECK QUICK DELIVERY / MAKE-UP AIR SYSTEMS:



DGK, DG, DGX
Make-Up Air Systems

DGK	DG	DGX	Options and Accessories
•	•	•	Insulated Housing
	•	•	Air Filter Gauge
•	•	•	Intake Dampers
•	•	•	Gas Pressure Regulator
•	•	•	Fiberglass Insulation
•	•	•	Inlet Air Sensor
	•	•	Combination Curb Extension
•	•	•	Roof Curbs
•	•	•	Duct Adapter
•	•	•	Weatherhood
•	•	•	Propane Gas
	•	•	Freezestat
	•	•	Discharge Diffuser
	•	•	Double Wall Construction
	•	•	Exhaust Fan Starter
		•	Variable Volume
		•	Recirculation
		•	Thru-Wall Mounting
	•	•	Evaporative Cooling
	•	•	Remote Control Panels
	•	•	115 volt Service Receptacle
•	•	•	Discharge Temperature Control
	•	•	Room Override
	•	•	Room Temperature Control
		•	DDC interface

Make-Up Air Systems - DGK, DG, DGX:

The Greenheck models, DGK, DG, DGX are designed to provide heated make-up air for commercial and industrial applications. The direct gas-fired burner provides a 100% efficient heating system with an ETL label. Airflow capacities up to 15,000 cfm and heating capacities up to 1,600,000 Btu/Hr are available. Installation may be stand-alone or on a combination package with exhaust fan on a common curb.

Optional Evaporative Cooling (DG & DGX):

The evaporative cooling section includes a galvanized steel housing with a louvered intake, 2 in. aluminium mesh filters and a stainless steel evaporative cooling module. The evaporative cooling media is Munters GLASdek and has a depth of 12 in. for 90% cooling effectiveness.

Standard Construction Features:

- Galvanized steel construction
- Control center with starter and disconnect
- Vibration isolation
- Factory wired and tested
- ETL label
- V-Bank filters (DG & DGX)

Performance:

Performance capabilities are 15,000 cfm with up to 2 in. of wg. of static pressure.

Optional Remote Panel:

Remote panels feature a variety of control switches and indicator lights mounted on a Permatecor coated galvanneal steel box.

GREENHECK QUICK DELIVERY / MAKE-UP AIR SYSTEMS:

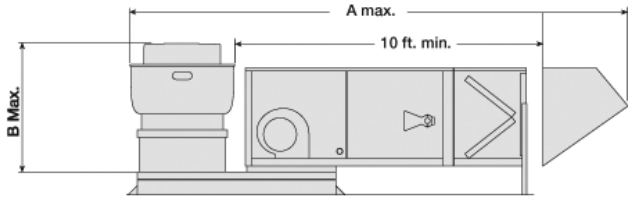

**DGK, DG, DGX - Direct Fire GAS
(Combination Package - Arrangement DBC)**

DGX Dimensions	Housing Size	ARR, DBC		
		A	B	Width
	H10	179	46	30
	H20	200	54	40
	H30	225	62	52

DG Dimensions	Housing Size	ARR, DBC		
		A	B	Width
	H12	171	46	33
	H22	225	54	44
	H32	261	62	52

All dimensions are in inches.

Combination Packages - DG & DGX

The Greenheck combination kitchen package simplifies installation and reduces firms labor costs. The pre-engineered design ensures tat the supply fan, exhaust fan, curb and combination extension components interface properly. Equally important, Greenheck combination packages are specifically designed to comply with FPA 06.

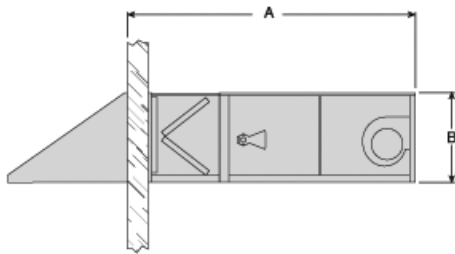

**ERV - Energy Recovery Ventilations
(Thru Wall Arrangement)**

DGX Dimensions	Housing Size	Thru Wall Mount		
		A	B	Width
	H12	122	40	33
	H22	145	46	36
	H32	160	49	52

All dimensions are in inches.

Thru-Wall Installation - DGX

Model DGX is available with a pre-engineered, thru-wall installation option, which is ideal when a roof penetration is not desirable.

Factory options that facilitate easy installation and ensure problem-free operation:

Weatherhood: A full down turn design with generous intake area to minimize intake velocity and moisture entertainment.

Thru-Wall Sleeve: Sleeve provides attachment interface between weatherhood and burner section Accommodates walls up to 15 inches in depth.

Filter Section: Aluminum mesh media filters outdoor air and strips fine mist from the air. A drain pan weeps moisture out of the front of the wall sleeve.

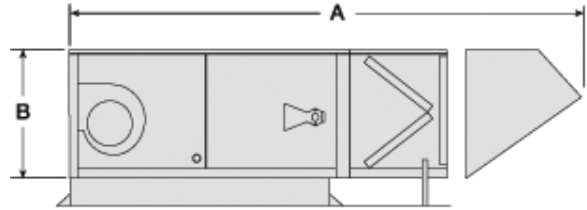
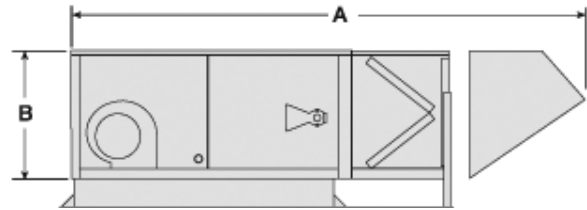

**ERV
Energy Recovery Ventilations
(1. Downblast Discharge - Arrangement DB
2. Horizontal Discharge - Arrangement HZ)**

DGK Dimensions	Housing Size	ARR, DB/HZ		
		A	B	Width
	H15	108	30	32

DG Dimensions	Housing Size	ARR, DB/HZ		
		A	B	Width
	H10	131	34	28
	H20	148	34	36
	H30	160	42	48

DGX Dimensions	Housing Size	ARR, DB/HZ		
		A	B	Width
	H12	127	40	33
	H22	160	46	44
	H32	1920	49	52

All dimensions are in inches.

Stand-Alone Arrangements - DGK, DG, DGX

Model DGK, DG, DGX are available for either downblast (Arrangement DB) or horizontal (Arrangement HZ) discharge. An upblast discharge (Arrangement UB) is also available on the DGX.



IG, IGX
Indirect Gas-Fired Make-Up Air

IG	IGX	Options and Accessories
•	•	Aluminized Steel Heat Exchanger
•	•	Stainless Steel Heat Exchanger
•	•	Air Filter Gauge
•	•	Motorized Damper
•	•	Exhaust Fan Starter(s)
•	•	Inlet Air Sensor
•	•	Evaporative Cooling
•	•	115V Service Receptacle
•	•	Roof Curb
•	•	Freezestat
•	•	Propane Gas
•	•	Duct Adapter
•	•	Double Wall Construction
•	•	Gas Pressure Regulator
•	•	Mixing Box
•	•	Evaporative Cooling
•	•	Remote Control Panel(s)
•	•	Modulating Control (4:1, 2:1 turndown)
•	•	Staged Control (8:1, 2:1 turndown)
•	•	DDC Temperature Control

Indirect Gas-Fired Make-Up Air - IG, IGX:

The Greenheck models IG and IGX feature 80% efficient indirect gas fired furnace(s) that are ETL listed. Heating capacity ranges from 75,000 to 1,200,000 BTU/hr and airflow volumes are available up to 15,000 cfm.

Standard Construction Features:

- Power vented
- Galvanized steel construction
- Control center with starter and disconnect
- Vibration isolation
- Factory wired and tested
- ETL label
- V-Bank filters
- ETL listed for indoor and Outdoor installation to ANSI standard z63.8 - 2002 and CGA Standard 2.6-2002
- 80% thermal efficiency
- Electronic staged or modulating gas controls
- Direct spark ignition system
- Easy access burner controls
- Insulated double wall furnace section construction

Combination Packages:

The evaporative cooling section includes a galvanized steel housing with a louvered intake, 2 in. aluminium mesh filters and a stainless steel evaporative cooling module. The evaporative cooling media is Munters GLASdek and has a depth of 12 in. for 90% cooling effectiveness.

Stand-Alone Arrangements:

Models IG and IGX are available for either downblast (Arrangement DB) or horizontal (Arrangement HZ) discharge.

Performance:

Performance capabilities are 15,000 cfm with up to 2 in. of wg. of static pressure.

Optional Evaporative Cooling:

The evaporative cooling section includes a galvanized steel housing with a louvered intake, 2 inch aluminium mesh filters and a stainless steel evaporative coding module. the evaporative cooling media is Munters CELdek or GLASdek with a depth of 12 inches for 90% cooling effectiveness.

The entire section mounts directly to the front of the unit, eliminating transition or duct-work by others.

GREENHECK IG - QUICK DELIVERY / MAKE-UP AIR SYSTEMS: 

GREENHECK IGX - QUICK DELIVERY / MAKE-UP AIR SYSTEMS: 

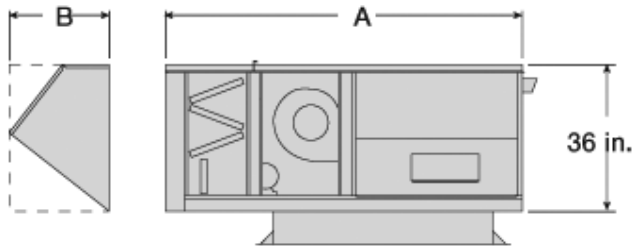

Stand Alone - Arrangement DB/HZ

Housing Size	ARR, DB/HZ		
	A	B	Width
H10	96	26	44
H20	93	26	53
H30	102	26	53

All dimensions are in inches and include mixing box and standard weatherhood. For roof opening dimensions and locations refer to factory submittal.

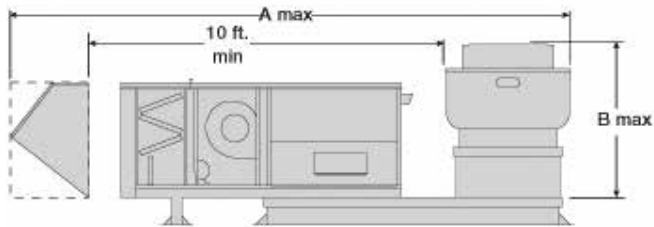

Combination Package - Arrangement DBC

Housing Size	ARR, DBC		
	A	B	Width
H10	182	56	48
H20	483	56	53
H30	181	56	53

All dimensions are in inches.
 * "A" dimension for units with only furnace.
 add 33in. for each additional furnace.
 * Furnace section width is 44in. for 200 MBH and 250 MBH furnace sizes.

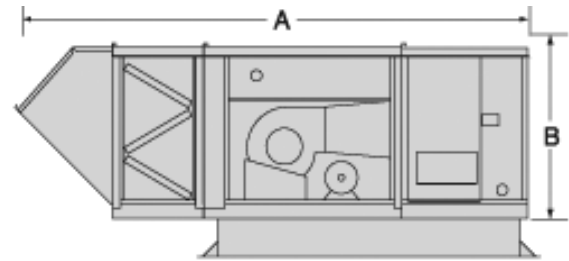

Stand Alone - Arrangement DB/HZ

Housing Size	ARR, DB/HZ		
	A	B	Width
H12	122	46	33+
H22	*140	46	44
H32	*173	49	52

All dimensions are in inches.

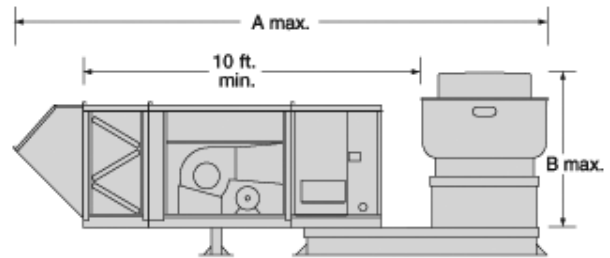

Combination Package - Arrangement DBC

Housing Size	ARR, DBC		
	A	B	Width
H12	166	46	33+
H22	*206	54	44
H32	*242	52	52

All dimensions are in inches.
 * "A" dimension for units with only furnace.
 add 33in. for each additional furnace.
 * Furnace section width is 44in. for 200 MBH and 250 MBH furnace sizes.

GREENHECK QUICK DELIVERY / CEILING CABINET & INLINE EXHAUSTERS:

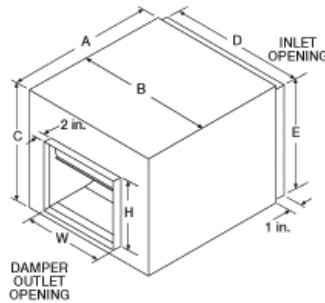

BDF
Ceiling Exhaust Belt Drive

Greenheck Fan Corporation certifies that the BDF models shown here are licensed to bear the AMCA Seal. The ratings shown are based on tests and procedures performed in accordance with AMCA Standard 211 and AMCA Publication 311 and comply with the requirements of the AMCA Certified Ratings Program.

BDF Standard Performance & Dimensional Data

Model	A	B	C	Damper Outlet Opening (WxH)	Inlet Opening (DxE)	Min/Max CFM	Sones @ 0.25in	Performance in inches w.g.				
								0.000	0.250	0.750	1.250	1.750
BDF-80	23 ¹ / ₄	18 ¹ / ₂	15 ⁷ / ₈	9 ³ / ₄ x 8 ⁷ / ₈	15 ³ / ₁₆ x 12 ¹¹ / ₁₆	400	4.7	373	717			
						1100	10.8	1025	1183	1404	1660	
BDF-90	24 ¹ / ₄	21 ³ / ₄	18 ³ / ₄	12 ¹ / ₄ x 10 ¹ / ₂	18 ¹ / ₄ x 15 ⁷ / ₈	800	4.1	334	584			
						1850	11.4	771	884	1113	1318	1506
BDF-100	26 ¹ / ₄	22 ³ / ₄	20 ³ / ₄	13 ³ / ₄ x 11 ⁷ / ₈	19 ³ / ₄ x 17 ⁷ / ₈	950	4.8	303	515			
						2150	11.0	688	747	960	1165	
BDF-120	33	27 ¹ / ₄	22 ³ / ₄	16 x 13 ³ / ₈	24 ¹ / ₅ x 18 ⁷ / ₈	1250	4.9	247	433			
						3050	13.3	604	645	815	985	
BDF-150	34 ³ / ₄	32 ⁵ / ₈	27 ³ / ₄	19 ¹ / ₈ x 16 ³ / ₈	28 ⁵ / ₈ x 23 ⁷ / ₈	2200	5.7	289	382			
						4900	18.7	643	686	769	853	977
BDF-180	40 ¹ / ₄	41 ³ / ₄	31 ³ / ₄	22 ¹ / ₂ x 18 ⁷ / ₈	37 ¹ / ₂ x 27 ⁷ / ₈	3000	5.7	169	321			
						7200	18.8	453	508	621	732	831
BDF-200	50 ¹ / ₄	49 ¹ / ₄	39 ³ / ₄	23 ¹ / ₈ x 25 ¹ / ₄	45 ¹ / ₆ x 36	5000	12.5	222	310	464		
						17000	42	755	783			

All dimensions in inches.

Performance certified is for installation type D: Ducted inlet, Ducted outlet. Power rating (BHP/kW) does not include transmission losses/ Performance ratings do not include the effects of accessories. The sound ratings shown loudness values in fan sones at 5ft. (1.5m) from the test inlet duct in a hemispherical free field calculated per AMCA standard 301. Values shown are for installation type D: ducted inlet, ducted outlet. Ratings do not include the effects of duct end correction.

Ceiling Exhaust Belt Drive - BDF:

BDF are belt drive duct fans. These fans are designed for low sound levels in supply, exhaust or ducted return applications. Forward curved wheels provide high efficiency with low sound levels.

Standard Construction Features:

- Galvanized steel housing and forward curved wheel
- Side access panels
- Motor and drive frame isolated on shock mounts
- Inlet and outlet duct connection flanges
- Ball bearing motors
- Fan Shafts mounted in ball bearings
- Adjustable motor pulley
- Fan shaft pulley
- Static resistant belts

Options and Accessories:

- UL/cUL 705 electrical
- Insulation
- filter boxes
- Gravity and motorized dampers
- External isolators
- Dual drivers
- Greenheck coatings
- Top horizontal mounting arrangement

Performance:

Performance capabilities range from 400 cfm to 17,000 cfm and up to 2.5 in. of wg. of static pressure.

VMC Vibration Isolators compatible with this Fan:

Complete isolator kits are available with spring rubber isolators. The isolators are sized to match the weight of the fan. (Hanging rods supplied by others)

Hanging Spring

THE VMC GROUP
The Power of Together™

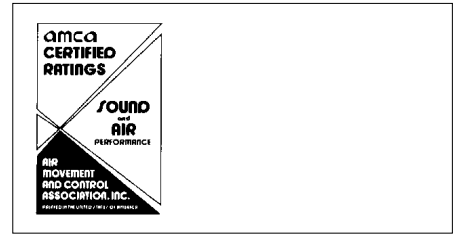
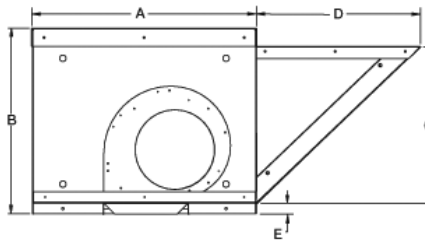

SAF
Supply Air Fan

SAF Standard Condensed Performance & Dimensional Data

Model	A	B	C	D	E	Recommended Roof Opening	Stock Sizes	CFM	Performance in inches w.g.							
									0.125	0.250	0.500	1.000	1.500	2.500	3.000	3.500
SAD-110	30	25	21 ¹ / ₁₆	22	1 ¹ / ₂	16 ¹ / ₂ x 16 ¹ / ₂	•	820	432	549						
								1720	688	757	883	1110	1307			
								2620	977	1032						
SAD-112	34	32 ¹ / ₈	27 ³ / ₈	29 ³ / ₄	2	20 ¹ / ₂ x 20 ¹ / ₂	•	1250	390	483						
								3000	697	743	843	1026	1179			
								3750	849	888	962					
SAF-115	34	32 ¹ / ₈	27 ³ / ₈	29 ³ / ₄	2	26 ¹ / ₂ x 26 ¹ / ₂	•	1300	316	407	546					
								2350	432	498	610	800	952	1139		
								4800	780	815						
SAF-118	40	36 ¹ / ₁₆	31 ¹ / ₁₆	32	2	32 ¹ / ₂ x 32 ¹ / ₂	•	2500	294	359	466					
								5500	514	550	620	743	851	1042	1134	
								8500	760	786	831					
SAF-120	46	48 ¹ / ₁₆	44 ¹ / ₁₆	35 ¹³ / ₁₆	2 ¹ / ₆	38 ¹ / ₂ x 38 ¹ / ₂	•	4000	275	325	414	553				
								9000	513	538	591	687	772	928	995	1060
								14000	772	791						

All dimensions in inches.

Performance certified is for installation type A: Free Inlet, Free outlet. Power rating (BHP) does not include transmission losses.

Performance ratings include the effects filters in the airstream.

General:

The SAF (Supply Air Fan) is a roof mounted, non-tampered, filtered, belt driven made-up air unit. This most effective forward curved supply fan performs similar to the RSF and KSFB. Housing is straight sided heavy gauge galvanized steel.

Performance:

Performance capabilities 725 cfm to 14,000 cfm and up to 3¹/₂ in. wg. of static pressure.

GREENHECK QUICK DELIVERY / DAMPERS:



ICD-45
Insulated Control Damper

General:

The ICD-45 damper is typically used in applications where it is necessary to minimize the transfer of heat or cold penetration and reduce condensation.

Standard Construction Features:

- Aluminum hat channel frame thermally broken with two polyurethane resin gaps and insulated on four sides with polystyrene
- Thermally broken aluminum airfoil blades with polyurethane foam
- Silicone blade and jamb seals
- Dual bearing with acetal inner sleeve and flanged cutter bearing



Greenheck Fan Corporation certifies that the ICD-45 models shown here are licensed to bear the AMCA Seal. The ratings shown are based on the procedures performed in accordance with AMCA Publication 511 and comply with the requirements of the ACMA Certified Ratings Programs. The AMCA Certified Ratings Seal applies to air performance ratings only.



Manual
Balancing Dampers

General:

Greenheck's Manual Balancing Dampers are designed to regulate flow of air in an HVAC system. They are used to accomplish system balancing. Each damper is equipped with a locking quadrant which fixes the damper blades in place after adjustment. These dampers are not intended to be used in applications as a positive shut off or for automatic control.

Standard Construction Features:

- Galvanized Steel
- Fabricated to your size requirements

Standard Construction Features:

- Stand-off brackets (accommodates for the additional thickness of insulated duct)
- Bronze bushings (MBD-15 only)
- Factory sleeves (MBD-15 only) : - (20 Ga.): 16, 21 inches
- (16 Ga.): 16, 21 inches
- (14 Ga.): 16, 21 inches
- Transitions: Oval, round, rectangular (MBD-15 only)

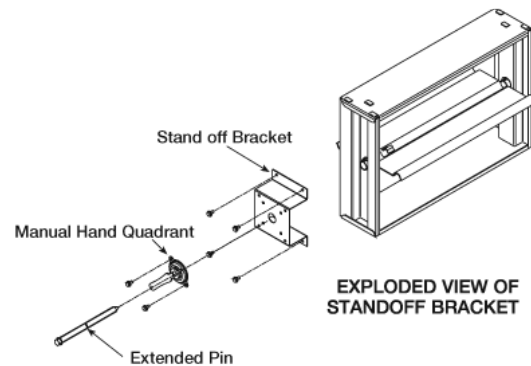

PRICE ZE445M - EXTRUDED ALUMINUM LOUVER:

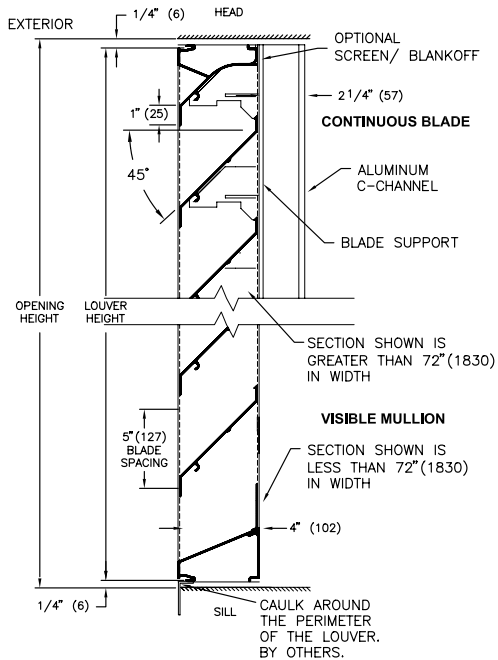

“A” Mounting

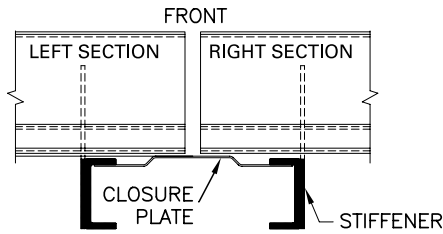

Continuous Blade Option

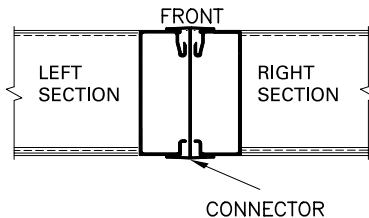

Visible Vertical Mullion (Standard)

Louver Type	Visible Mullion or Continuous Blade
Material	Extruded Aluminum (Alloy 6063-T5)
Stationary Blade	.081" (2 mm)
Frame	.081" (2 mm)
Louver Depth	4" (102 mm)
Blade Angle	45°
Performance Rating Standard	AMCA Standard 500
Wind Load	25 psf (100 mph)
Free Area - 4' x 4' Unit	7.92 sq.ft. (0.736 sq.m.)
Percent Free Area	49.5%
Free Area Velocity at Beginning Point of Water Penetration (1)	669 FPM (204 m/min)
Air Volume Delivered at Beginning Point of Water Penetration (1)	5,298 CFM (150 m³/min)
Pressure Drop at Beginning Point of Water Penetration (1)	0.09" H ₂ O (23 Pa)

Features:

- “Z” Blade Profile.
- .081” Extruded Aluminum Blades and Frames.
- Nominal 49.5% free area (based on 48”x 48”).
- Integral perimeter caulking stop.
- 1/2” x 1/2” (12 x 12) 16 gauge Expanded Aluminum Bird Screen without frame.
- Mill finish.

Options:

- Welded Construction.
- Extended Sill (loose) 14 GA. Aluminum.
- Continuous Blade Sections (invisible mullions).
- Blank-offs are available in Aluminum with or without Insulation. Insulation is available in 1”, 1.5”, 2”, or 3” thickness.
- Variety of Mounting options.
- Exterior or Interior Frame Mounting.
- Variety of Bird Screens, Insect Screens and Frames available.
- Wide variety of Finishes: Baked Enamel, Prime Coat, Custom Finishes, Clear Anodized and Colour Anodized.
- Select from PRICE Colour Chart or provide colour sample to match.
- Note: Colour variations can be expected within the same order and even on the same louver due to the anodizing process.

PRICE DE439M - EXTRUDED ALUMINUM LOUVER:

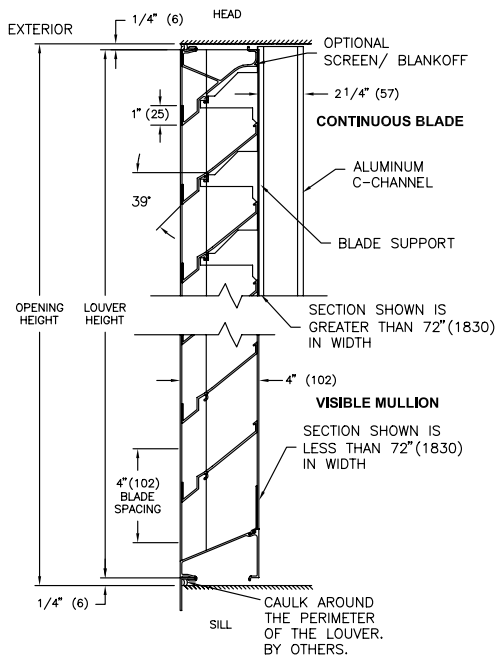

“A” Mounting

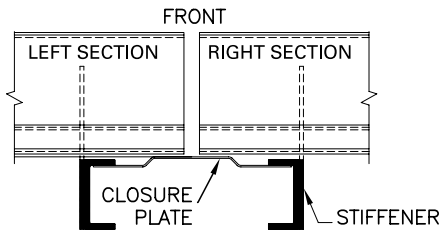

Continuous Blade Option

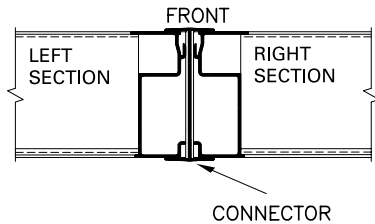

Visible Vertical Mullion (Standard)

Louver Type	Visible Mullion or Continuous Blade
Material	Extruded Aluminum (Alloy 6063-T5)
Stationary Blade	.081" (2 mm)
Frame	.081" (2 mm)
Louver Depth	4" (102 mm)
Blade Angle	39°
Performance Rating Standard	AMCA Standard 500
Wind Load	25 psf (100 mph)
Free Area – 4' x 4' Unit	8.57 sq.ft. (0.736 sq.m.)
Percent Free Area	53.6%
Free Area Velocity at Beginning Point of Water Penetration (1)	886 FPM (270 m/min)
Air Volume Delivered at Beginning Point of Water Penetration (1)	7,589 CFM (215 m ³ /min)
Pressure Drop at Beginning Point of Water Penetration (1)	0.13" H ₂ O (3 Pa)

Features:

- Drainable Blade.
- .081" Extruded Aluminum Blades and Frames.
- Nominal 53.6% free area (based on 48"x 48").
- Integral perimeter caulking stop.
- 1/2" x 1/2" (12 x 12) 16 gauge Expanded Aluminum Bird Screen without frame.
- Mill finish.

Options:

- Welded Construction.
- Extended Sill (loose) 14 GA. Aluminum.
- Continuous Blade Sections (invisible mullions).
- Blank-offs are available in Aluminum with or without Insulation. Insulation is available in 1", 1.5", 2", or 3" thickness.
- Variety of Mounting options.
- Exterior or Interior Frame Mounting.
- Variety of Bird Screens, Insect Screens and Frames available.
- Wide variety of Finishes: Baked Enamel, Prime Coat, Custom Finishes, Clear Anodized and Colour Anodized.
- Select from PRICE Colour Chart or provide colour sample to match.
- Note: Colour variations can be expected within the same order and even on the same louver due to the anodizing process.

PRICE FIRE DAMPERS - CURTAIN TYPE:

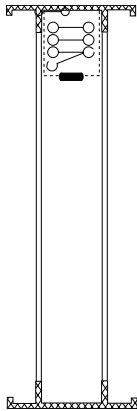

FD-VA
In the Airstream Fire Damper

6 x 6	18 x 12
8 x 8	18 x 18
10 x 10	20 x 12
12 x 18	20 x 20
12 x 12	24 x 4
14 x 10	24 x 12
14 x 14	24 x 14
16 x 8	24 x 24
16 x 16	

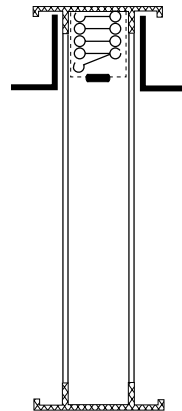

FD-VB
Out of the Airstream Fire Damper

6 x 4	14 x 14
6 x 6	16 x 10
8 x 6	16 x 12
8 x 8	16 x 16
10 x 6	18 x 4
10 x 8	18 x 6
10 x 10	18 x 18
12 x 8	20 x 20
12 x 10	24 x 12
12 x 12	24 x 16
14 x 4	24 x 24
14 x 10	

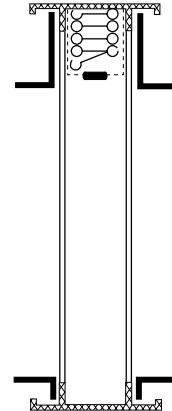

FD-VC
Rnd, Out of the Airstream Fire Damper

4"	10"
5"	12"
6"	14"
7"	16"
8"	

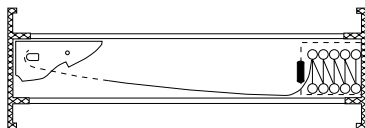

FD-HA
In the Airstream Fire Damper

6 x 6	14 x 14	18 x 18
8 x 8	16 x 8	20 x 20
10 x 10	16 x 16	24 x 12
12 x 6	18 x 12	24 x 24
12 x 12	18 x 18	

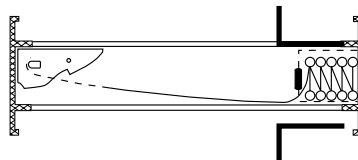

FD-HB
Out of the Airstream Fire Damper

6 x 6	12 x 12	18 x 18
8 x 8	14 x 14	20 x 12
10 x 10	16 x 8	20 x 20
12 x 6	16 x 16	24 x 12
12 x 10	18 x 12	24 x 24

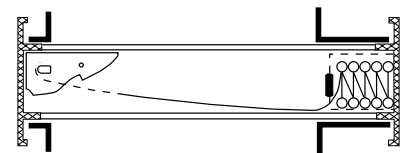

FD-HA
Rnd, Out of the Airstream Fire Damper

4"	7"	12"
5"	8"	14"
6"	10"	18"

PRICE FIRE DAMPERS - CURTAIN TYPE:

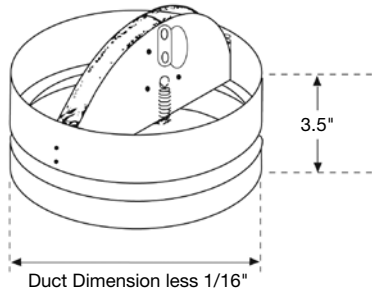

Round Ceiling Dampers

Size	Diameter	Height
6	6	3.5
8	8	3.5
10	10	3.5
12	12	3.5
14	14	3.5

Round Ceiling Dampers are available in two models, butterfly-type (non-asbestos) or the same with adjustable volume controller.

PRICE CFS - CEILING FIRE STOP FLAPS:

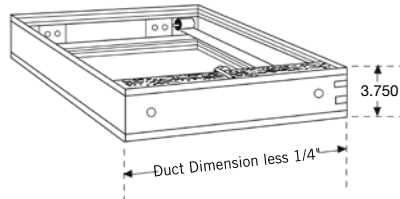

Square Rectangular Ceiling Dampers

Size	Length	Width	Height
12 x 12	12	12	3.75
24 x 12	24	12	3.75
24 x 24	24	24	3.75

Square and Rectangular Ceiling Dampers are available in two models, square or rectangular, non-asbestos.

PRICE THERMAL BLANKETS:

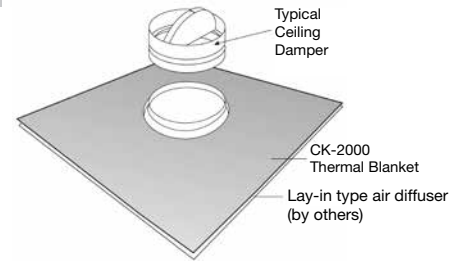

Thermal Blankets

Thickness	Fan Model & Size
1/8"	CK-200-1
1 1/4"	CK-2000-1-B

Lightweight, non-asbestos fabric can be easily installed in the field. Allows for ceiling openings larger than duct size.

PRICE OVAL ACCESS DOORS:



Oval Access Doors

Model	Dimensions (inches)
AD0805	8 x 5
AD1206	12 x 6
AD1810	18 x 10
AD2214	22 x 14
AD2618	26 x 18

BELIMO ACTUATORS:



Two Position, Spring Return Actuators

LF120 (35"-lb Torque)
NF120 (60"-lb Torque)
AF120 (133"-lb Torque)
LF120-S (c/w End Switch)
NF120-S (c/w End Switch)
AF120-S (c/w End Switch)

Modulating SPRV

LF24-SR-S (35"-lb Torque) (c/w End Switch)
NF24-SR-S (60"-lb Torque) (c/w End Switch)
AF24-MFT-S (133"-lb Torque) (c/w End Switch)

Honeywell ACTUATORS:



ML Series

MS Series

ML 4115A1009
ML 4115B1008
ML 8115A1005B
ML 8115A1004
MS 4209F
MS 4120F1204

Fast-Acting, Two-Position Actuators for fire/Smoke Applications. Note: Other models are available upon request.



VMC GROUP
THE POWER OF TOGETHER

ISOLATORS:



HSA
Hanging Spring Isolator

Model	Spring Color	Rated Load LB/KG	Rated Deflection in/mm
HSA-1B-20	Dark Blue	20/9	1.25/32
HSA-1B-35	Black	35/16	1.17/30
HSA-1B-50	Red	50/23	1.11/28
HSA-1B-70	Dark Green	70/32	0.88/22
HSA-1C-100	Tan	100/45	1.00/25
HSA-1C-150	Ref	150/88	1.00/25
HSA-1C-250	Black	250/113	0.83/21
HSA-1C-300	Dark Yellow	300/136	0.75/19
HSA-1C-370	Yellow	370/168	0.75/19

Series "HS" or "HSA" Hangers VMC Series HS hangers provide excellent vibration isolation for suspended piping and equipment. They incorporate a color coded steel spring for ease of identification in the field. With load ranges from 20 lb. to 8,160 lb. and up to 5 inches of static deflection, these mounts offer a wide variety of choices to insure proper support.

Series HSA offers the above features plus the capability for the lower hanger rod to swing approximately 30° to compensate for rod misalignment. The 30° misalignment capability insures that the rod does not short circuit the hanger by coming in contact with the hanger box.



RD
Elastomeric Floor Mounted Isolator

Model	Spring Color	Rated Load LB/KG	Rated Deflection in/mm
RD-1-35	Blue	35/16	0.4/10.1
RD-1-45	Black	45/20	0.4/10.1
RD-1-70	Red	70/32	0.4/10.1
RD-1-120	Green	120/54	0.4/10.1
RD-2-170	Black	170/77	0.5/12.7
RD-2-240	Red	240/109	0.5/12.7

Series "RD" elastomeric isolators are molded in four sizes and can support up to 4000 lb. per isolator. They offer up to .5 inches of static deflection for excellent vibration isolation. All of our RD series isolators are molded completely in color for ease of identification, and all metal parts are completely embedded in neoprene for corrosion resistance. A tapped hole in the center of the mounting enables it to be securely bolted to the equipment.

Honeywell E³ POINT - TOXIC & COMBUSTIBLE GAS MONITOR

CO, NO₂, H₂S, H₂, O₂, CH₄, C₃H₈



Remote Sensor

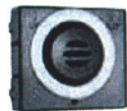

Sensor Cartridge

Make your operation run more intelligently to protect people, property and your bottom line. Protect parking structures, loading docks, transport terminals, hospital/ambulance bays, car washes, battery charging rooms and hydrogen tanks, commercial kitchens, indoor stadiums, outbuildings and more.

Note: Non-branded versions of this product are available upon request.

Flexible Operation

- Comes in standalone, standalone with remote (dual gas mode) or network versions
- Connect to analog or digital systems
- Works with virtually any BAS including BACnet or Modbus
- Wall or duct mount
- Factory-calibrated cartridges

Cost Effective

- Saves energy through Demand Control Ventilation (DCV)
- Simplifies installation/maintenance through plug-n-play sensor
- Remote sensor options provides dual gas monitoring (standalone version only)
- Optimizes BAS, fire, ventilation and other security systems

Versatile Communication

- Works through BAS to improve fault diagnostics and collect data on gas concentration levels, sensor condition, etc.
- Couple with 301C to log data and daisy-chain up to 96 E³Point units

Advanced Sensing Technology

- Detects CO, NO₂, H₂S, H₂, O₂, CH₄, C₃H₈
- Advanced electrochemical (for toxic gases) and catalytic bead (for combustible gases) sensor performance
- Uses patented Reflex[®] and smart cartridge technologies

Range of Accessories

- Factory-calibrated replacement cartridges
- Power transformer
- Vandal-resistant steel wire detector guards
- Tamper-proof screws
- Horns and strobes

Applications

- Parking Structure
- Loading Dock Transport Terminal
- Golf Cart Maintenance
- Battery Charging Area
- Maintenance Garage
- Hospital/Ambulance Bay
- Fire/Police Station
- Car Wash
- Battery Charging Rooms
- H₂ & Hydrogen Tanks
- Commercial Kitchen C₃H₈
- Boiler Rooms

Certifications

- Intertek Classified to: UL 61010-1; and CSA C22.2 No.61010-1-04
- COLA (City of Los Angeles) approved for carbon monoxide detection in commercial buildings and parking garages

Honeywell E³ POINT - TOXIC & COMBUSTIBLE GAS DETECTOR STAND-ALONE PLATFORM:

E3 Point - Toxic & Combustible Gas
Detector Stand-Alone Platform

Detection Ranges and Alarm Levels				
Gas	Resolution	Range	Alarm A	Alarm B
Carbon Monoxide (CO)	1 ppm	0-250 ppm	25 ppm	100 ppm
Hydrogen Sulphide (H ₂ S)	0.1 ppm	0-50 ppm	10 ppm	15 ppm
Nitrogen Dioxide (NO ₂)	0.1 ppm	0-16 ppm	0.7 ppm	2 ppm
Oxygen (O ₂)	0.1% vol.	0.25% vol.	19.5% vol.	22% vol.
Hydrogen (H ₂)	0.5% LEL	0-100% LEL	25% LEL	50% LEL
Methane (CH ₄)	0.5% LEL	0-100% LEL	25% LEL	50% LEL
Propane (C ₃ H ₈)	0.5% LEL	0-100% LEL	25% LEL	50% LEL

Uses:

Wall or duct-mounted gas detector for monitoring carbon monoxide (CO), nitrogen dioxide (NO₂), oxygen (O₂), methane (CH₄), hydrogen (H₂), hydrogen sulphide (H₂S), and propane (C₃H₈), installed as a stand-alone device with single-gas or dual-gas monitoring.

Size:

20.56 x 14.90 x 6.72cm (8.09 x 5.87 x 2.65") (H x W x D); Remote Sensor: 3.5 x 4.5 x 6.5cm (1.36 x 1.75 x 2.56")

Power Requirement:

24VAC nominal (17-27VAC), 50/60Hz, 0.4A; 24VDC nominal (20-38VDC); with remote sensor: 7 W max.

Optional Main AC Input:

120VAC nominal, +/- 10% (with on-board transformer)

Relay Output:

2 DPDT relays, 5A @ 250VAC; 5A @ 30VDC

Communications:

4-20mA

Operating Environment:

Commercial, Indoor, Extreme Temperature Environments

Operating Temperature:

H₂S, NO₂, CH₄, H₂, C₃H₈: -40 to 50OC (-40 to 122OF)

CO: -20 to 50OC (-4 to 122OF);

future available CO version: -40 to 50OC (-40 to 122OF)

Sensor Type:

Commercial, Indoor, Extreme Temperature Environments

Display:

8 character, 2 line black-lit LCD

Visual Indicators:

Green LED: Power

Amber LED 1: Alarm/Fault

Amber LED 2: Alarm Fault

Audible Alarm:

85 dBA at 3m (10ft.)

Accuracy:

+/- 3% of full scale @ 25 C

Enclosure:

Polycarbonate

Certification:

CSA C22.2 No. 61010-1, UL US UL 61010-1; FCC part 15; ICES-003 issue 4

Honeywell E³ POINT -TOXIC & COMBUSTIBLE GAS DETECTOR STAND-ALONE PLATFORM:



Honeywell E3 Point

* Base unit and sensor cartridge sold together

** Base unit only; sensor cartridge sold separately

Ordering Information	
Single-Gas Configuration: Base Unit, Surface-Mount	
Part Number	Description
E3SA, E3SCO	E ³ Point, CO sensor cartridge, Surface-mount, 24VAC/dc, -20 to 50°C (-4 to 122°F)
E3SA	E ³ Point, Surface-mount, 4-20mA, 24VAC/dc, -40 to 50°C (-40 to 122°F)
E3SAII, E3SCO	E ³ Point, CO sensor cartridge, Surface-mount, 120VAC, -20 to 50°C (-4 to 122°F)
E3SAH	E ³ Point, Surface-mount, 4-20mA, 120VAC, -40 to 50°C (-40 to 122°F)
Remote Sensors (always sold with sensor cartridge included)	
Part Number	Description
E3SRMCO	E ³ Point, Remote Sensor, -20 to 50°C (-4 to 122°F), Carbon Monoxide
E3SRMNO2	E ³ Point, Remote Sensor, -20 to 50°C (-4 to 122°F), Nitrogen Dioxide
E3SRMH2S	E ³ Point, Remote Sensor, -20 to 50°C (-4 to 122°F), Hydrogen Sulfide
E3SRMH2	E ³ Point, Remote Sensor, -20 to 50°C (-4 to 122°F), Hydrogen
E3SRMO2	E ³ Point, Remote Sensor, -20 to 50°C (-4 to 122°F), Oxygen
E3SRMM	E ³ Point, Remote Sensor, -20 to 50°C (-4 to 122°F), Methane
E3SRMP	E ³ Point, Remote Sensor, -20 to 50°C (-4 to 122°F), Propane
Stand-Alone Platform, Duct-Mount	
Part Number	Description
E3DA, E3SCO	E ³ Point, CO, Duct-mount, 24VAC/dc, -20 to 50°C (-4 to 122°F)
E3DA	E ³ Point, Duct-mount, 4-20mA, 24VAC/dc, -40 to 50°C (-40 to 122°F)
Sensor Cartridges	
Part Number	Description
E3SCO	CO Cartridge -20 to 50°C (-4 to 122°F), Carbon Monoxide
E3NO2	NO ₂ Cartridge -20 to 50°C (-4 to 122°F), Carbon Monoxide
E3H2S	H ₂ S Cartridge -20 to 50°C (-4 to 122°F), Carbon Monoxide
E3H2	H ₂ Cartridge -20 to 50°C (-4 to 122°F), Carbon Monoxide
E3O2	O ₂ Cartridge -20 to 50°C (-4 to 122°F), Carbon Monoxide
E3M	CH ₄ Cartridge -20 to 50°C (-4 to 122°F), Carbon Monoxide
E3P	C ₃ H ₈ Cartridge -20 to 50°C (-4 to 122°F), Carbon Monoxide
Examples on how to order	
To order a stand-alone version, surface-mount, analog, CO detector, -20 to 50°C (-4 to 122°F): Order E3SA, E3SCO	
To order a stand-alone version, surface-mount, analog, dual-gas CO+NO ₂ , -20 to 50°C (-4 to 122°F): Order E3SA, E3SCO + E3SRMN02	
To order a stand-alone version, duct-mount, analog, propane-detector, -40 to 50°C (-40 to 122°F): Order E3DA + E3P	
To order a stand-alone version, surface-mount, analog, dual-gas CO + C ₃ H ₈ , 120VAC, -20 to 50°C (-4 to 122°F): Order E3SAH, E3SCO + E3SRMP	

Honeywell E³ POINT -TOXIC & COMBUSTIBLE GAS DETECTOR STAND-ALONE PLATFORM:



VA 301EM-20

The VA 301EM-20 acts as a controller for up to 20 remote sensors and suits a variety of gas detection system solutions for Mechanical Rooms.

Particularly configured to meet ASHRAE 15, B-52 and International Mechanical Code requirements, the VA301EM is commonly used to optimize gas detection in mechanical and chiller rooms. A full complement of sensors (including toxic, oxygen, combustible gases and a full line of refrigerant sensors), horns, strobes and remote panels provide added flexibility to suit a variety of gas detection system solutions.

ASHRAE No 15 Mechanical Standard and B-52 Code Compliance

The ASHRAE and B-52 security standards have been established to minimize risk and protect the safety of mechanical room personnel and the environment at large. Available in a special configuration, the VA301EM mechanical room controller has been carefully designed to meet and even exceed these rigorous standards. The VA 301EM can be configured to offer automatic fan, horn and strobe activation in addition to manual fan activation. Latching relay for manual alarm recognition, silence key for manual horn deactivation, built-in 24 Vdc outputs for horn operation, and 2 break-glass switch accessories for manual alarm activation ensure optimal performance.

User Friendly

- Easy to read LCD display
- Auto-diagnostic capabilities

Economical Solution

- Cost-effective answer for installation in Mechanical Rooms locations

Flexible Operation

- Able to operate with up to 20 remote sensors at a time
- Various types of sensors available to simultaneously detect a range of different Refrigerant, Toxic and Combustible gases
- Robust and reliable RS-485 Modbus communication

Output Adaptability

- Three 24 Vdc alarm outputs and four 4-20 mA outputs

Safety Measures

- Four fully programmable relays
- Three alarm levels with built-in visual indicators and audible alarm

Beneficial Options

- Convenient stand-alone or network operation

Use:

Wall mounted mechanical room controller for use with Honeywell Analytics range of gas sensors. Four (4) on board relays can be used to activate alarms or deactivate equipment.

Size:

28 x 20.3 x 7cm (11.02 x 7.99 x 2.73")

Power Requirement:

22-27VAC, 29-38VDC, 2A max @ 29VDC

Weight:

1.02kg (2.25lb.)

Distance Between Controller and Sensor:

VA301rfs refrigerant sensors: Up to 200ft./60.9m
S301D2 toxic/combustible sensors: Up to 500ft. / 152.4m

Visual Indicators:

Normal Operation - Green LED
Alarm Level 1 - Red LED
Alarm Level 2 - Red LED
Alarm 3 - Red LED
Signal Tx - Blinking Amber LED
Failure Indication - Yellow LED

Alarm Levels:

3 with high and low setpoints

Outputs:

4 DPDT relays (alarms and/or fault), buzzer
Three 24VDC, 250 mA (per output)
Four 4-20 mA outputs

Modbus

RFS option: 24VDC built-in red strobe
RFSa option: 24VDC built-in red strobe & 105 dBA horn

Relay Output Rating:

5A, 30 VDC or 250 VAC (resistive load):
Certified to  CAN/CSA C22.2 No. 61010-1 116662
Conforms to ANSI/UL 61010-1

Gases Detected			
Gases Detected	Detection Range	Operating Temperature	Operating Humidity Range
VA301IRFS			
R11, R22, R123, R125, R134A, R404A, R407C, R410A, R507A	0-1000 ppm	0 to 40°C (32 to 104°F)	0-95% non-condensing
S301D2			
Hydrogen Sulphide (H ₂ S)	0-50 ppm	-40 to 40°C (-40 to 104°F)	0-90% RH, non-condensing 0-90% RH, non-condensing 5-95% RH, continuous
Carbon Monoxide (CO)	0-250 ppm	-20 to 40°C (-4 to 104°F)	
Oxygen (O ₂)	0-25%	-20 to 40°C (-4 to 104°F)	
Nitrogen Dioxide (NO ₂)	0-10 ppm	-20 to 40°C (-4 to 104°F)	
Sulfur Dioxide (SO ₂)	0-10 ppm	-20 to 40°C (-4 to 104°F)	
Combustible - Catalytic	0-100% LEL	-40 to 40°C (-40 to 104°F)	
ECFX-EM			
Ammonia NH ₃	0-100 ppm	-50 to 120°C (ATMOS)	5-100% RH

Accuracy is +/- 3% for IFRS and D2 sensors. +/- 5% for EC-F9 sensor



APU - CARROLL ECOLOGY UNIT - GREASE / POLLUTION CONTROL EXHAUSTER:



BUILDING AUTOMATION STARTERS:

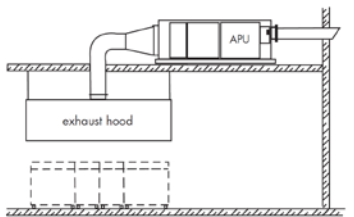

Indoor / Horizontal Supported

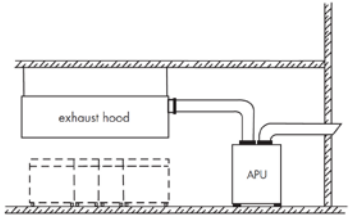

Indoor / Vertical Supported

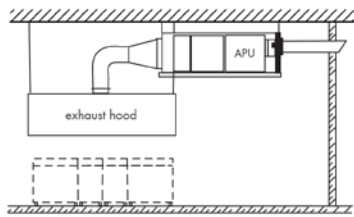

Indoor / Horizontal Suspended

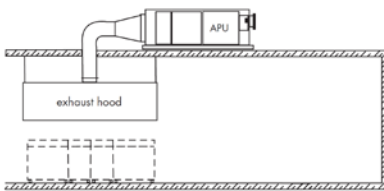

Outdoor / Horizontal Roof Mounted

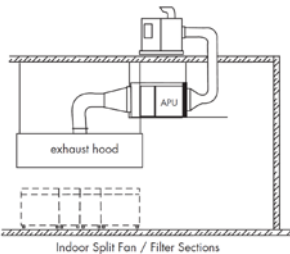

Indoor Split Fan / Filter Sections

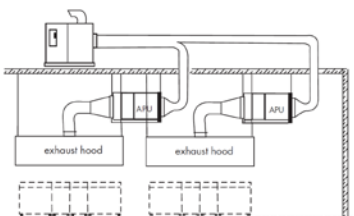

Indoor Split Fan / Multiple Filter Sections (Mall Applications)

Applications:

The EnvironAir® APU is available in a variety of configurations to meet the food service operators requirements for the elimination of particulate grease, smoke, and/or odor from the kitchen exhaust air stream. Integrated or stand alone modules are available for the blower/fan, filter, and odor control functions of the system. Installation can be in a ceiling space above the kitchen ventilator, or in a remote location such as a utility room, or on the roof top. The EnvironAir® APU provides the food service operator an economical solution to problems which in the past would have prevented the installation of a commercial kitchen operation. EnvironAir® solves the problems associated with the following installation problems:

New High-Rise Buildings

EnvironAir® provides the economical solution to the cost of running expensive 16 gauge all welded duct-work to the roof of new high rise buildings. The cleaned kitchen exhaust air from the EnvironAir® unit can be exhausted out the side of the building at a minimum 10' (3 meters) above ground level or into another area of the building such as an underground parking garage. In the United States all duct-work is required to be 16 gauge all welded steel.

Existing High-Rise Buildings

EnvironAir® is the solution to running kitchen exhaust duct work in existing buildings where it is impossible or cost prohibitive to run all welded duct-work to the roof. The cleaned kitchen exhaust air from the EnvironAir® unit can be exhausted out the side of the building at a minimum 10' (3 meters) above ground level or into another area of the building such as an underground parking garage. In the United States all duct-work is required to be 16 gauge all welded steel.

Mall Operations With Food Courts

EnvironAir® provides pollution control for new and existing Mall Food Court operations and the flexibility for future expansion of the system. Multiple hoods and APU filter sections can be joined to common odor control and blower sections of the system.

Kitchen Exhaust Odor Abatement

EnvironAir® will effectively control the malodors produced from commercial cooking operations when equipped with the optional Odor Control Section. This option addresses the problems of commercial kitchens located near residential areas or areas that are under pollution control requirements from their local Air Quality Management District or other local authorities.

Reduced Duct-work Cost In Canada

In Canada, and in conjunction with the EnvironAir® ULC Listing, all exhaust duct-work downstream of the filter section can be installed with standard HVAC requirements (non-welded, galvanized, standard clean air installation). Exhaust air can be discharged at levels other than rooftop (i.e. side wall or parking garage), thereby eliminating costly continuously welded horizontal and vertical duct runs and fire barrier chases. Duct-work from the hood to the inlet of the EnvironAir® unit is required to be 16 gauge all welded steel.



BAS-1P

1Ø Starter for Smart Buildings

Applications:

- Concealed hand/auto switch discourages tampering
- Lockable motor-rated On/Off switch meets safety regulations
- Meets UL/NEC/NFPA service disconnect requirements when properly installed
- LED indicator lights for power, run and fault

Run Status Verification:

- Integrated current sensing confirms motor operational status
- Quickly and accurately pinpoint malfunctioning equipment

Voltage & Dry Inputs for Auto Run Command:

- Wire directly from the automation system to the starter no interposing relays necessary
- Save on installation costs and increase reliability

System Override Mode (Fireman's Occupancy or Manual):

- Initiates smoke purge sequence during emergency situations for safety and code compliance or use for occupancy sensor run in out (dry contact)

Wide Range Class 10 Electronic Overload:

- Prevent ordering confusion and eliminates call backs cue to mid-sized heaters.
- Advanced protective features including anti-cycling, manual/auto reset, etc.

Standard Single Gang Box Installation:

- Easy to install in any location
- Surface or flush mount capability

High Reliability:

- Heavy duty motor-rated switch and control relay
- No thermal elements to fail
- All units include a 5-year warranty
- UL 508A Listed

FRANKLIN BUILDING AUTOMATION STARTERS:



BAS : UL Type 1

- UL Type 1 for indoor use
- Lockable cover prevents unauthorized access/tampering
- Standard conduit knock-outs top and bottom for easy installation
- Combination version features motor circuit protector to provide branch and short circuit protection

UL Type 1 - Indoor Enclosure Standard Magnetic H-O-A Starters (Electronic Overload)									
HP				SCIC KAIC @ 460 V	NEMA Size				
Three Phase					00	0	1	2	3
200V	230V	400V	575V		BAS Part Number				
1	1.5	3	3	5	BAS1-9/J-5				
3	5	10	15	5		BAS1-18/J-22			
7.5	10	20	25	5			BAS1-32/J-40		
15	15	30	50	5				BAS1-50/J-80	
20	25	50	60	10					BAS1-85/J-80

UL Type 1 - Indoor Enclosure Combination Magnetic H-O-A Starters (Electronic Overload)									
HP				SCIC KAIC @ 460 V	NEMA Size				
Three Phase					00	0	1	2	3
200V	230V	400V	575V		BAS Part Number				
-	-	3/4	3/4	65	BAS1-9/J-G1.6-5	BAS1-18/J-G1.6-5			
1/2	1/2	1	1.5	65	BAS1-9/J-G2.5-5	BAS1-18/J-G2.5-5			
3/4	3/4	2	36	65	BAS1-9/J-G4-5	BAS1-18/J-G4-5			
1	1.5	3	3	65	BAS1-9/J-G6-5	BAS1-18/J-G6-5			
2	2	5	5	65		BAS1-18/J-G8-22			
2	3	5	7.5	65		BAS1-18/J-G10-22			
3	3	7.5	10	65		BAS1-18/J-G13-22			
3	5	10	15	30		BAS1-18/J-G17-22	BAS1-32/J-G17-40		
5	7.5	15	20	30			BAS1-32/J-G22-40		
7.5	7.5	15	20	30			BAS1-32/J-G26-40	BAS1-50/J-G26-80	
7.5	10	20	25	30			BAS1-32/J-G32-40	BAS1-50/J-G32-80	
10	10	30	30	50				BAS1-50/J-G40-80	BAS1-85/J-G40-80
15	15	30	40	50				BAS1-50/J-G50-80	BAS1-85/J-G50-80
20	20	40	50	50					BAS1-85/J-G63-80
20	25	50	60	50					BAS1-85/J-G75-80

FRANKLIN P-SERIES VFD:

TAMCO DAMPERS



- 1-40HP (200~230VAC), 1-75HP (575~600VAC), 3Ø
- Dual Rated for Constant & Variable Torque
- Integrated PID Control

- Space Vector control for efficiency and long motor life
 - Cleaner sine wave as compared to typical V/Hz control. Motors run cooler and last longer.
- Advanced PID control (Pre-PID and Dual PID)
 - Maintain a constant control of pressure, low or water level. This function includes
 - Pre-PID, Sleep and Wake up and output inverse sub-functions
 - Dual PID for external PID control or cascade PID control
 - Multi-Motor
- Multi-motor control function
 - Control up to 4 motors
- Automatic energy savings mode
 - Adaptive flux control for varying loads (e.g. damper loading)
- Sleep and wake up function
 - Increased energy savings by deactivating drive during low demand
- Flying start protection
 - Prevents trips, rough starts, and drive damage from regenerative power from heavy fan inertia rotation
- Flux braking algorithm
 - Reduces deceleration time for enhanced system efficiency
- Pre-heater function
 - Used to protect motor and inverter from damage when installed in damp location (e.g. green house).
- Automatic carrier frequency change
 - Adjusts based on temperature for optimal operation
- Selectable V/F, Sensorless vector control
 - Ideal for any control requirement
- Long-life condenser & simple framework
 - Increased reliability
- Built-in Modbus RTU communication
 - Optional: Profibus-DP, LonWorks, BACnet, Modbus



TAMCO 9000
Aluminum Thermally Insulated Control Dampers
*Opposed Blade & In-Duct Mounting

12 x 12	24 x 24
16 x 16	36 x 12
24 x 12	36 x 36



TAMCO 1000
Aluminum Air Foil Control Dampers
* Opposed Blade & In-Duct Mounting

12 x 12	24 x 24
16 x 16	36 x 12
24 x 12	36 x 36

ORTECH FANS



FANS

Ortech OD-1106	110 CFM Fan @ 0.6 sones
Ortech OD-9003	90 CFM Fan @ 0.3 sones
Ortech ODS-1109	110 CFM Fan @ 0.9 sones



FIRE-RATED ADJUSTABLE Z-BLADE LOUVER: 1900A REV A



This Adjustable Z-Blade Louver with Fusible Link is Ideal for Use in Fire Doors up to 1-1/2 Hour Rating.
Ideal for Installation in Existing Door Cutouts.

Specifications	
Materials	18 gauge (.048") CRS frame. Min size 10" x 6", Max 24" x 24".
Construction	Louvers: Z-blade louvers riveted to operating bar and frame at 1" intervals to welded 1-9/16" deep frame. Mechanical stop 5/8" x 3/8" x 16 ga. (.048") holds blades open. Frame: Mitered and welded corners; screws fastened through prepared frame into louver core leaving corridor side of frame free of fasteners.
Operation	Adjustable blades of 16 gauge (.059") CRS pivot on cadmium-plated steel rivets. The blades are operated by a manual adjusting lever. A spring loaded fusible link mechanism is incorporated into the design. Upon melting of the link at 165° F, the action bar is actuated, thereby closing and locking all of the blades.
Door:	For 1-3/4" steel or composite doors. Door cutout = order size.
Fastener:	#8 x 3/4" Phillips flathead screws to match finish.
Powder Coat Finishes:	___ (B) Mineral Bronze (standard color) ___ (G) Gray Primer ___ (BK) Black ___ (FBK) Flat Black ___ (W) White ___ (SB) SC Beige ___ (SI) Silver ___ (S) Sand ___ (AB) AMS Beige ___ (R) Red ___ (GH) Gray Hammertone Color Samples Online
Free Flow Area:	45% free area.

Optional Features at an additional cost	
Finishes & Materials:	___ (S) 18 gauge (.048") stainless steel frame and 16 gauge (.059") louver blades— #4 finish. ___ (E) Electro Galvanized for corrosion resistance & exterior use.
Fasteners:	___ Torx ___ Other: _____
Screen:	___ Insect or ___ Bird Screen.
Door:	___ 1-3/8" Door
Custom:	Custom sizes, other door thickness. Contact Customer Service.

Order Format:	1900A	_____	_____	_____	_____
Example: 1900A 1212SA	Option S,E	W	H	Color	

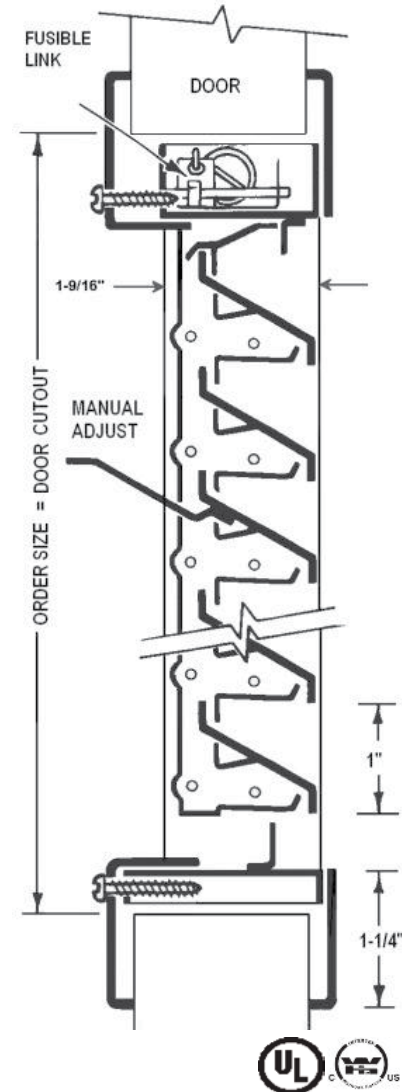

LISTINGS & RATINGS:

Fire Ratings with UL & WHI Classification Marks

Tested & Listed for UL10(b), and classified in accordance with UBC7-2-94, ASTM E152, CAN/ULC S104, NFPA 252. Install in accordance with NFPA80.

Model 1900A is Rated for use in fire doors up to 1-1/2 hour rating. Louver size shall not exceed maximum of 576 sq. inches, 24"W and 24" H. The minimum width and height shall not be less than 10" and 6", respectively. Louvers may be provided for classified hollow metal type and composite type fire doors.

Consult with the Local Authority Having Jurisdiction (AHJ) to determine appropriate standards. Louver frame will be labeled with Listing mark.

E.H. PRICE TORONTO

571 Chrislea Road, Unit 3,
Woodbridge, ON Canada L4L 8A2
Ph: **905.669.8988** Fax: **905.669.8023**
Email: toronto@ehpricesales.com
Website: www.ehpricetoronto.com



Specifications are subject to change without notice. Consult your E.H. Price sales representative for current specifications or more detailed information.

Warranty: The Company warrants and guarantees that all goods within this brochure that have been manufactured by the Company have been manufactured in accordance with the specifications published herein and will be free from defects in material and workmanship for a period of twelve (12) months from the Bill of Lading issued by the Company. The Company will replace defective product at its option, but will not be responsible for labor or material charges in replacing product or consequential damages. Any installation not conforming with the Company's specifications, manuals, bulletins or instructions or any misuse or any modification not authorized by the Company voids this warranty. This warranty is in lieu of all Provincial, State, and Federal statutory warranties and the conditions herein are in substitution and replacement of which warranties, statutory or otherwise.

e.h.price

First in Quality, First in Service

ehpricetoronto.com